

**Model 72959  
SMA PLUG R/A CRIMP, RG141, 174, 188, 316**

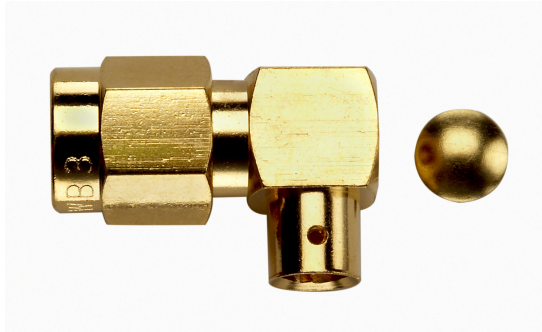

Model 72959 SMA PLUG R/A CRIMP, RG141, 174, 188, 316

High bandwidth, small size, and durability for confident connections.

**Features**

- DC – 12.4 GHz
- Meets MIL-C-39012, IEC 169-15, CECC 22110.
- Small size and durability for mobile communications.
- Precision machined and gold-plated for low loss.

**Materials**

- Body is machined brass with gold plating.
- Center Contacts - Plug is gold plated brass and Jack is gold plated Beryllium copper.
- Insulators are high quality PTFE.
- Crimp Ferrules are copper with gold or nickel plating.
- Gaskets are silicone rubber.

**Ordering Information**

Model: 72959  
Description: SMA PLUG R/A CRIMP, RG141, 174, 188, 316

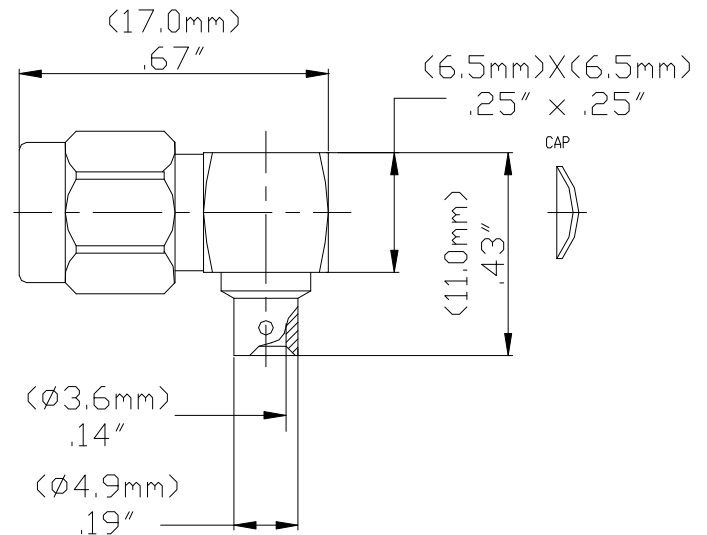

**Specifications**

Impedance	50 Ω
Frequency Range	0-12.4 GHz on flexible cable
Working Voltage	< 375 Vpeak
Dielectric Withstanding Voltage	1,000 Vrms
VSWR	1.4 max.
Center/Outer Contact Resistance	0.003/0.002 Ω max
Insulation resistance	> 5000 MΩ
Number of Insertions	500 cycles minimum
Temperature Range	-65° C to 165° C, -85° F to 329° F

**USA:** Sales: 800-490-2361  
Technical Support: [technicalsupport@pomonaest.com](mailto:technicalsupport@pomonaest.com)  
Fax: 425-446-5844

**Europe:** 31-(0) 40 2675 150 **International:** 425-446-5500

**Where to Buy:** [www.pomonaelectronics.com](http://www.pomonaelectronics.com)

All dimensions are in inches. Tolerances (except noted): .xx = ±.02" (.51 mm), .xxx = ±.005" (.127 mm). All specifications are to the latest revisions. Specifications are subject to change without notice. Registered trademarks are the property of their respective companies.  
D2003394 REV 001

**Model 72959**  
**SMA PLUG R/A CRIMP, RG141, 174, 188, 316**

**Cable Assembly Instructions**

1. CUT CABLE END EVENLY AND PERPENDICULAR

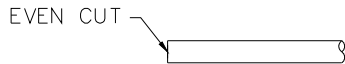

2. STRIP CABLE JACKET, BRAID, AND DIELECTRIC TO SPECIFICATION LENGTHS.

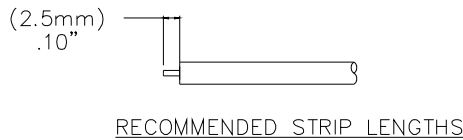

3. SLIDE CABLE THROUGH CONNECTOR BODY UNTIL CABLE CENTER CONDUCTOR ENGAGES WITH CENTER CONTACT ON CONNECTOR. SOLDER CABLE CENTER CONDUCTOR TO CONNECTOR CENTER CONTACT AND SCREW ON CAP.

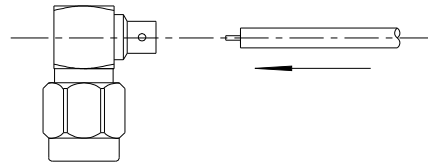

4. SCREW ON CAP AS SHOWN.

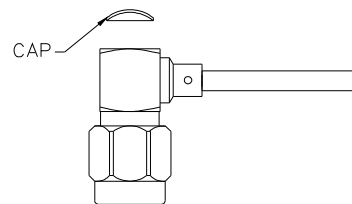

**USA:** Sales: 800-490-2361  
Technical Support: [technicalsupport@pomonatest.com](mailto:technicalsupport@pomonatest.com)  
Fax: 425-446-5844  
**Europe:** 31-(0) 40 2675 150    **International:** 425-446-5500  
**Where to Buy:** [www.pomonaelectronics.com](http://www.pomonaelectronics.com)

All dimensions are in inches. Tolerances (except noted): .xx =  $\pm .02$ " (.51 mm), .xxx =  $\pm .005$ " (.127 mm). All specifications are to the latest revisions. Specifications are subject to change without notice. Registered trademarks are the property of their respective companies.  
D2003394 REV 001