

**Model 4934**  
**Do-It-Yourself In-Line Sheathed Banana Jack**

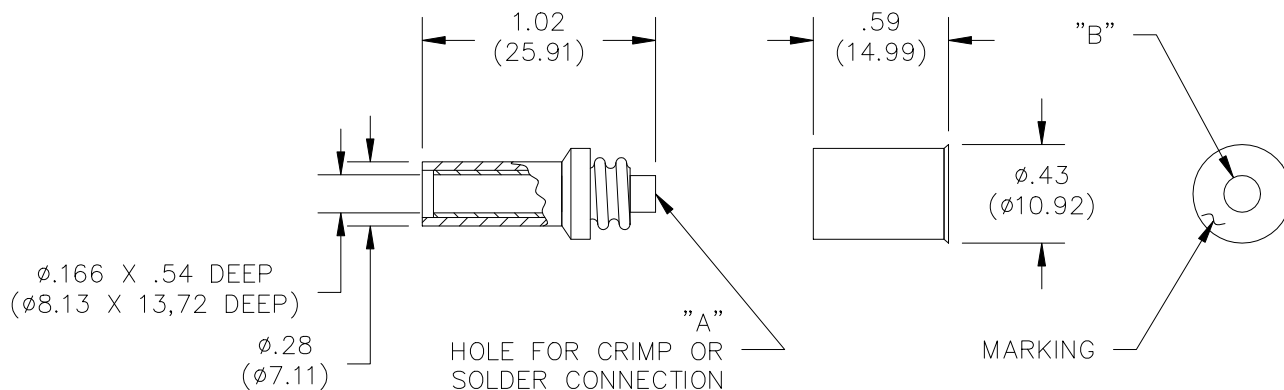

Model #	Dimension "A"	Dimension "B"	Accepts Wire AWG
4934	.062" (1.57mm)	.160" (4.06mm)	18, 20, 22

**Features**

- Threaded two piece design allows wires to be soldered or crimped to the banana jack body.
- Fits with Pomona models 4933 and 4986 Banana Plugs.

**Materials**

*Banana Jack Body* – Brass, Nickel Plated

*Insulation* – Polypropylene, color per part number

*Threaded Handle* – Polypropylene, color per part number

*Marking* – "POMONA ELECT." & part number



**Ratings**

Operating Voltage: Hands free usage in controlled voltage environments: 1200 Vrms Max.

*For CE compliance:* not intended for hand-held use at voltages above 33 Vrms/70 Vdc.

Operating Temperature: +80°C (+176°F)

Current: 15 Amperes Max.

**Ordering Information**

Model: 4934-Color

Colors = -0 (Black), -2 (Red)

Ordering Example: 4934-2 (Banana Jack with Red insulation)

**USA:** Sales: 800-490-2361  
Technical Support: [technicalsupport@pomonatest.com](mailto:technicalsupport@pomonatest.com)  
Fax: 425-446-5844

**Europe:** 31-(0) 40 2675 150 **International:** 425-446-5500

**Where to Buy:** [www.pomonaelectronics.com](http://www.pomonaelectronics.com)

All dimensions are in inches. Tolerances (except noted): .xx = ±.02" (.51 mm), .xxx = ±.005" (.127 mm). All specifications are to the latest revisions. Specifications are subject to change without notice. Registered trademarks are the property of their respective companies.