

Resistivity Measurements of Semiconductor Materials Using the 4200A-SCS Parameter Analyzer and a Four-Point Collinear Probe

APPLICATION NOTE



Introduction

Electrical resistivity is a basic material property that quantifies a material's opposition to current flow; it is the reciprocal of conductivity. The resistivity of a material depends upon several factors, including the material doping, processing, and environmental factors such as temperature and humidity. The resistivity of the material can affect the characteristics of a device of which it's made, such as the series resistance, threshold voltage, capacitance, and other parameters.

Determining the resistivity of a material is common in both research and fabrication environments. There are many methods for determining the resistivity of a material, but the technique may vary depending upon the type of material, magnitude of the resistance, shape, and thickness of the material. One of the most common ways of measuring the resistivity of some thin, flat materials, such as semiconductors or conductive coatings, uses a four-point collinear probe. The four-point probe technique involves bringing four equally spaced probes in contact with a material of unknown resistance. A DC current is forced between the outer two probes, and a voltmeter measures the voltage difference between the inner two probes. The resistivity is calculated from geometric factors, the source current, and the voltage measurement. The instrumentation used for this test includes a DC current source, a sensitive voltmeter, and a four-point collinear probe.

To simplify measurements, the 4200A-SCS Parameter Analyzer comes with a project that contains tests for making resistivity measurements using a four-point collinear probe. The 4200A-SCS can be used for a wide range of material resistances including very high resistance semiconductor materials because of its high input impedance ($>10^{16}$ ohms). This application note explains how to use the 4200A-SCS with a four-point collinear probe to make resistivity measurements on semiconductor materials.

The Four-Point Collinear Probe Method

The most common way of measuring the resistivity of a semiconductor material is by using a four-point collinear probe. This technique involves bringing four equally spaced probes in contact with a material of unknown resistance. The probe array is placed in the center of the material, as shown in **Figure 1**.

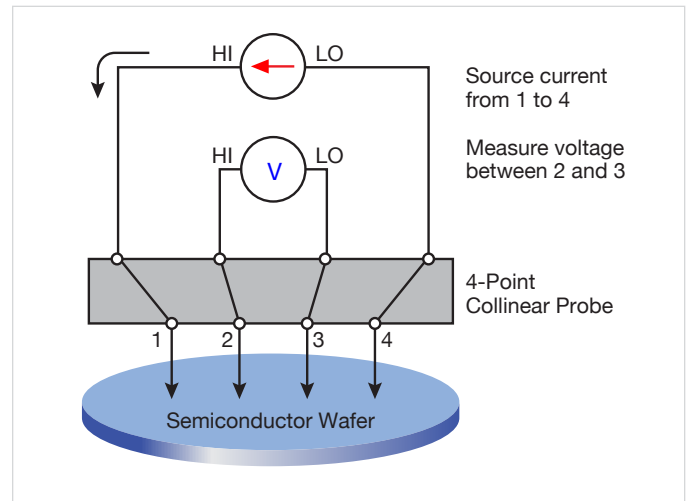

Figure 1. Four-point probe resistivity test circuit

The two outer probes are used for sourcing current and the two inner probes are used for measuring the resulting voltage drop across the surface of the sample. The volume resistivity is calculated as follows:

$$\rho = \frac{\pi}{\ln 2} \times \frac{V}{I} \times t \times k$$

- where:
- ρ = volume resistivity (Ω -cm)
 - V = the measured voltage (volts)
 - I = the source current (amperes)
 - t = the sample thickness (cm)
 - k^* = a correction factor based on the ratio of the probe to wafer diameter and on the ratio of wafer thickness to probe separation

* The correction factors can be found in standard four-point probe resistivity test procedures such as SEMI MF84-02—Test Method for Measuring Resistivity of Silicon Wafers with an In-Line Four-Point Probe.

For some materials such as thin films and coatings, the sheet resistance, or surface resistivity, is determined instead, which does not take the thickness into account. The sheet resistance (σ) is calculated as follows:

$$\sigma = \frac{\pi}{\ln 2} \frac{V}{I} \quad k = 4.532 \frac{V}{I} \quad k$$

where:

σ = the sheet resistance (Ω /square or just Ω)

Note that the units for sheet resistance are expressed in terms of Ω /square in order to distinguish this number from the measured resistance (V/I).

Using the Kelvin Technique to Eliminate Lead and Contact Resistance

Using four probes eliminates measurement errors due to the probe resistance, the spreading resistance under each probe, and the contact resistance between each metal probe and the semiconductor material. **Figure 2** is another representation of the four-point collinear probe setup that shows some of the circuit resistances.

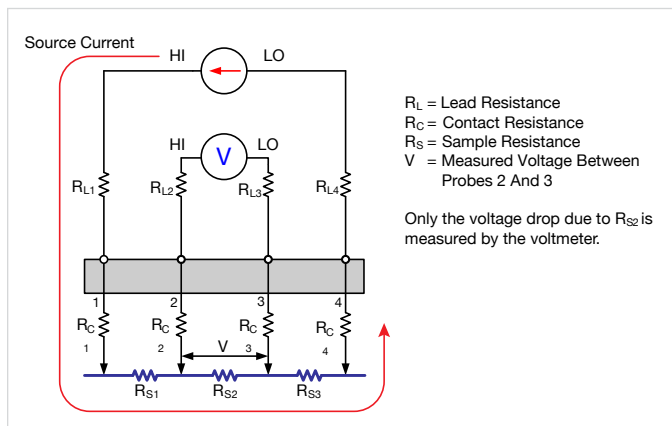

Figure 2. Test setup showing circuit resistances

The R_L terms represent the test lead resistance. R_C represents the contact resistance between the metal probe and the semiconductor material. The contact resistance can be several hundred to a thousand times higher than the resistance of the sample material, which is represented by R_S .

Notice that the current flows through all the resistances in the first and fourth set of leads and probes, as well as through the semiconductor material. However, the voltage is only measured between probes 2 and 3. Given that between probes 2 and 3, the current only flows through R_{S2} , only the voltage drop due to R_{S2} will be measured by the voltmeter. All the other unwanted lead (R_L) and contact (R_C) resistances will not be measured.

Using the 4200A-SCS to Make Four-Point Probe Collinear Probe Measurements

The 4200A-SCS comes with a project that is already configured for automating four-point probe resistivity measurements. The project, *Four-Point Probe Resistivity Project*, can be found in the Project Library in the Select view by selecting the Materials filter. This project has two tests: one measures the resistivity using a single test current and the other measures the resistivity as a function of a current sweep. These two tests, *Four-Point Probe Resistivity Measurement (4-pt-collinear)* and *Four-Point Probe Resistivity Sweep (4-pt-resistivity-sweep)*, can also be found in the Test Library and can be added to a project. A screen capture of the *Four-Point Probe Resistivity Measurement* test is shown in **Figure 3**.

The projects and tests included with the 4200A-SCS are configured to use either three or four SMUs (Source Measure Units). When using three SMUs, all three SMUs are set to Current Bias (voltmeter mode). However, one SMU will source current (pin 1 of probe) and the other two (pins 2 and 3 of probe) will be used to measure the voltage difference between the two inner probes. An example of how this is set up with the 4200A-SCS is shown in **Figure 4**. One SMU (SMU1) and the GNDU (ground unit) are used to source current between the outer two probes. The other SMUs (SMU2 and SMU3) are used to measure the voltage drop between the two inner probes.

When configuring the tests, enter an appropriate test current for SMU1. This will depend on the resistivity of the sample. For higher resistance samples, additional Interval time may need to be added in the Test Settings pane to ensure a settled reading.

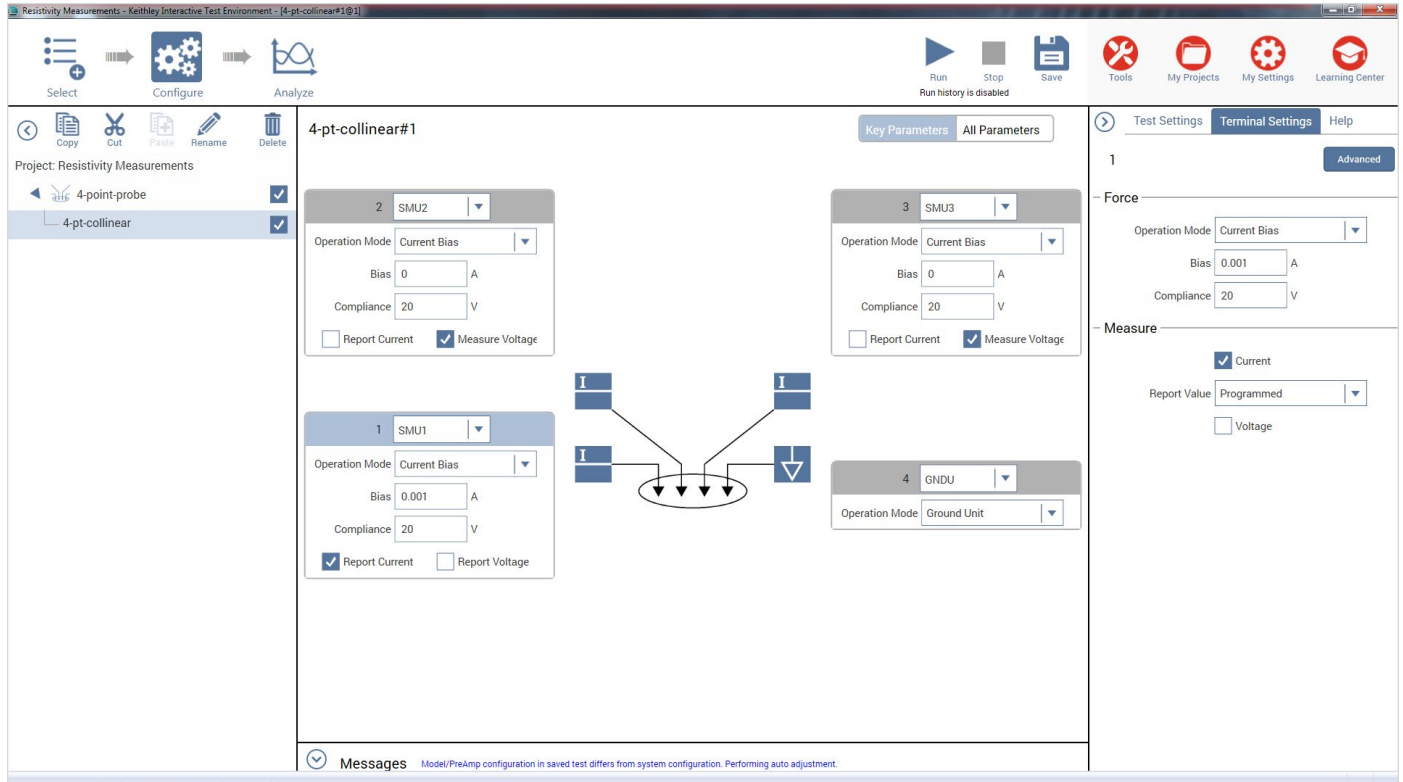

Figure 3. Screen Capture of Four-Point Probe Resistivity Measurement Test in the Clarius software

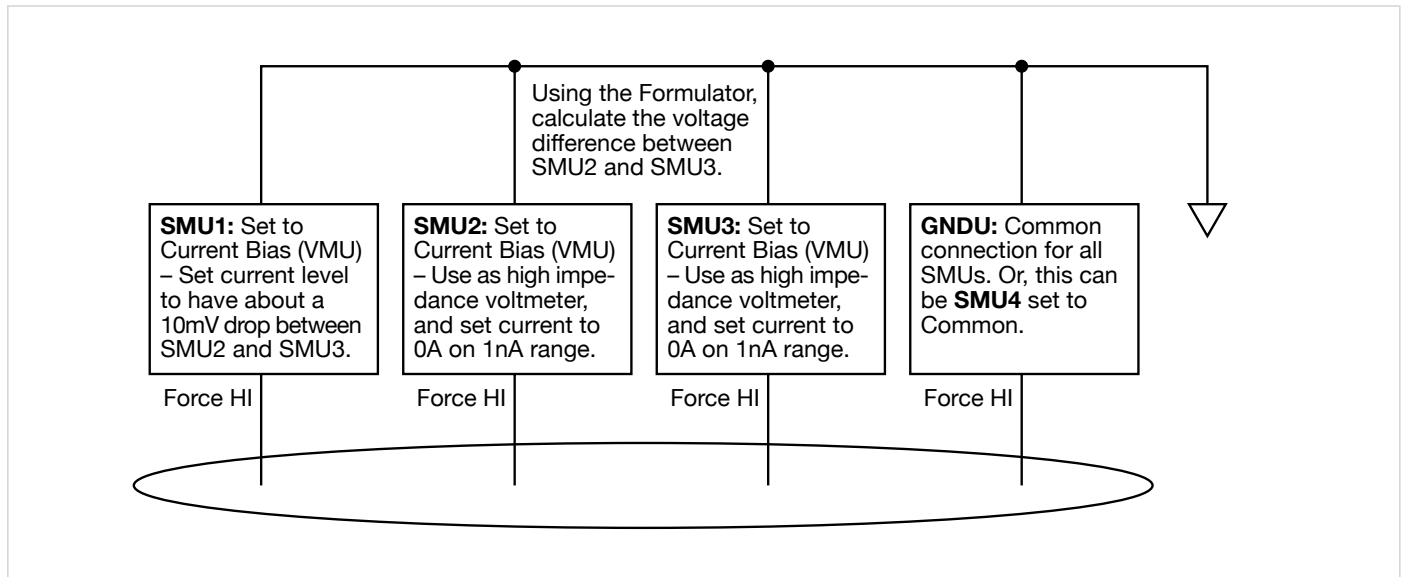

Figure 4. SMU Instrument Designation for Four-Point Collinear Probe Measurement

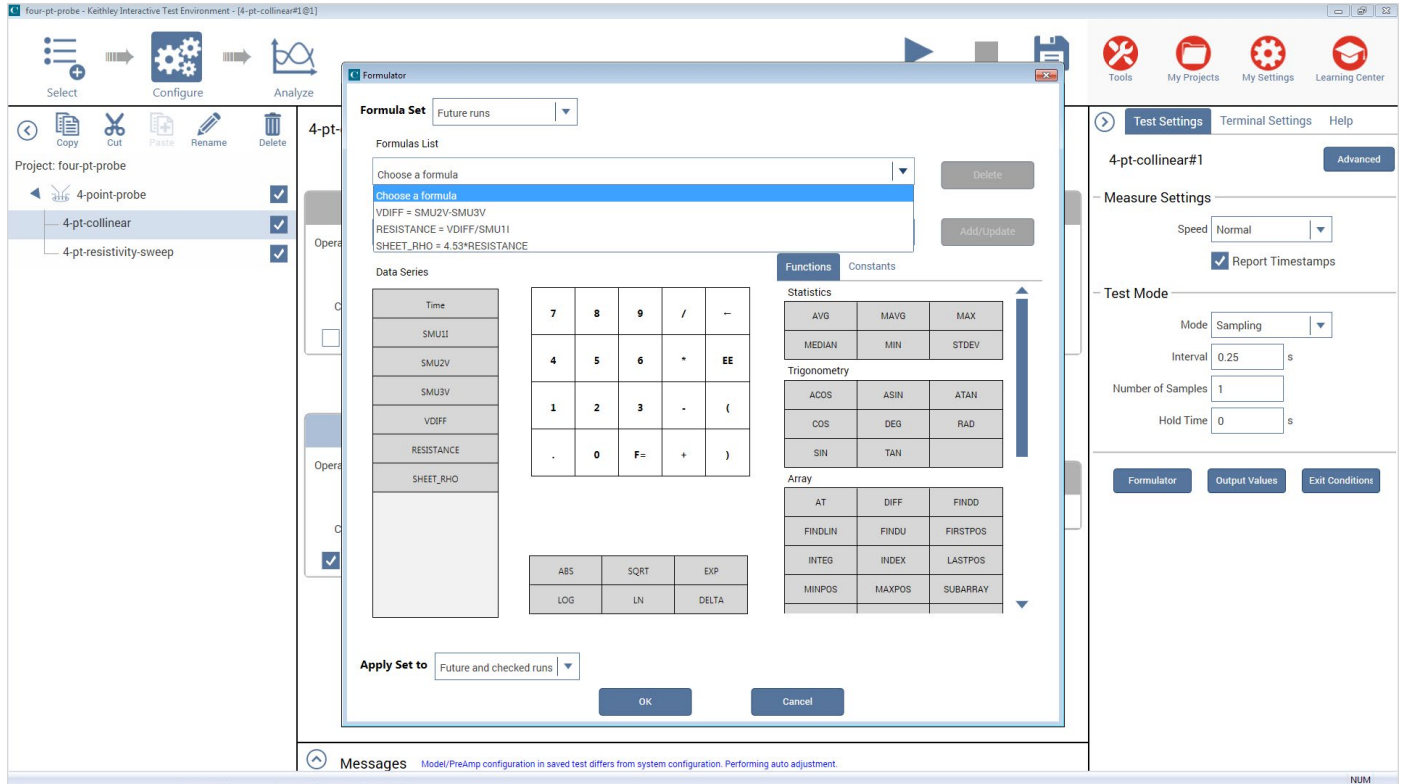

Figure 5. Formulator dialog box with resistivity calculations in the *Four Point Probe Resistivity Project*.

The Formulator in the Test Settings pane includes equations to derive the resistivity as shown in **Figure 5**. The voltage difference between SMU2 and SMU3 is calculated: $VDIFF = SMU2V - SMU3V$. The sheet resistivity (ohms/square) is derived from SMU1 current and voltage difference calculation, $SHEET_RHO = 4.532 * (VDIFF / SMU1I)$. To determine the volume resistivity (ohms-cm), multiply the sheet resistivity by the thickness of the sample in centimeters (cm). If necessary, a correction factor can also be applied to the formula.

After the test is configured, lower the probe head so the pins are in contact with the sample. Execute the test by selecting Run at the top of the screen. The resistivity measurements will appear in the Sheet in the Analyze view.

Sources of Error and Measurement Considerations

For successful resistivity measurements, potential sources of errors need to be considered.

Electrostatic Interference

Electrostatic interference occurs when an electrically charged object is brought near an uncharged object. Usually, the effects of the interference are not noticeable because the charge dissipates rapidly at low resistance levels. However, high resistance materials do not allow the charge to decay quickly and unstable measurements may result. The erroneous readings may be due to either DC or AC electrostatic fields.

To minimize the effects of these fields, an electrostatic shield can be built to enclose the sensitive circuitry. The shield is made from a conductive material and is always connected to the low impedance (FORCE LO) terminal of the SMU instrument.

The cabling in the circuit must also be shielded. Low noise shielded triax cables are supplied with the 4200A-SCS.

Leakage Current

For high resistance samples, leakage current may degrade measurements. The leakage current is due to the insulation resistance of the cables, probes, and test fixturing. Leakage current may be minimized by using good quality insulators, by reducing humidity, and by using guarding.

A guard is a conductor connected to a low impedance point in the circuit that is nearly at the same potential as the high impedance lead being guarded. The inner shield of the triax connector of the 4200A-SCS is the guard terminal. This guard should be run from the 4200A-SCS to as close as possible to the sample. Using triax cabling and fixturing will ensure that the high impedance terminal of the sample is guarded. The guard connection will also reduce measurement time since the cable capacitance will no longer affect the time constant of the measurement.

Light

Currents generated by photoconductive effects can degrade measurements, especially on high resistance samples. To prevent this, the sample should be placed in a dark chamber.

Temperature

Thermoelectric voltages may also affect measurement accuracy. Temperature gradients may result if the sample temperature is not uniform. Thermoelectric voltages may also be generated from sample heating caused by the source current. Heating from the source current will more likely affect low resistance samples, because a higher test current is needed to make the voltage measurements easier. Temperature fluctuations in the laboratory environment may also affect measurements. Because semiconductors have a relatively large temperature coefficient, temperature variations in the laboratory may need to be compensated for by using correction factors.

Carrier Injection

To prevent minority/majority carrier injection from influencing resistivity measurements, the voltage difference between the two voltage sensing terminals should be kept at less than 100mV, ideally 25mV, since the thermal voltage, kt/q , is approximately 26mV. The test current should be kept as low as possible without affecting the measurement precision.

Conclusion

The 4200A-SCS Parameter Analyzer is an ideal tool for measuring resistivity of semiconductor materials using a four-point collinear probe. The built-in resistivity project and tests are configurable and include the necessary calculations.

Bibliography

ASTM, F76-86. Standard Method for Measuring Hall Mobility and Hall Coefficient in Extrinsic Semiconductor Single Crystals. Annual Bk. ASTM Stds., 1999: 10.05.

SEMI MF84-02: Test Method for Measuring Resistivity of Silicon Wafers With an In-Line Four-Point Probe. Last published by ASTM International as ASTM F 84-02.

van der Pauw, L. J. A Method of Measuring Specific Resistivity and Hall Effects of Discs of Arbitrary Shape. Phips Rec. Repts., 1958: 13 1.

Schroder, Dieter K. *Semiconductor Material and Device Characterization*. John Wiley & Sons, Inc., 1998.

Low Level Measurements, Keithley Instruments, Inc., Cleveland, Ohio, 2014.

Contact Information:

Australia* 1 800 709 465
Austria 00800 2255 4835
**Balkans, Israel, South Africa
and other ISE Countries** +41 52 675 3777
Belgium* 00800 2255 4835
Brazil +55 (11) 3759 7627
Canada 1 800 833 9200
Central East Europe / Baltics +41 52 675 3777
Central Europe / Greece +41 52 675 3777
Denmark +45 80 88 1401
Finland +41 52 675 3777
France* 00800 2255 4835
Germany* 00800 2255 4835
Hong Kong 400 820 5835
India 000 800 650 1835
Indonesia 007 803 601 5249
Italy 00800 2255 4835
Japan 81 (3) 6714 3010
Luxembourg +41 52 675 3777
Malaysia 1 800 22 55835
**Mexico, Central/South America
and Caribbean** 52 (55) 56 04 50 90
Middle East, Asia, and North Africa +41 52 675 3777
The Netherlands* 00800 2255 4835
New Zealand 0800 800 238
Norway 800 16098
People's Republic of China 400 820 5835
Philippines 1 800 1601 0077
Poland +41 52 675 3777
Portugal 80 08 12370
Republic of Korea +82 2 6917 5000
Russia / CIS +7 (495) 6647564
Singapore 800 6011 473
South Africa +41 52 675 3777
Spain* 00800 2255 4835
Sweden* 00800 2255 4835
Switzerland* 00800 2255 4835
Taiwan 886 (2) 2656 6688
Thailand 1 800 011 931
United Kingdom / Ireland* 00800 2255 4835
USA 1 800 833 9200
Vietnam 12060128

* European toll-free number. If not accessible, call: +41 52 675 3777

Find more valuable resources at TEK.COM

Copyright © 2016, Tektronix. All rights reserved. Tektronix products are covered by U.S. and foreign patents, issued and pending. Information in this publication supersedes that in all previously published material. Specification and price change privileges reserved. TEKTRONIX and TEK are registered trademarks of Tektronix, Inc. All other trade names referenced are the service marks, trademarks or registered trademarks of their respective companies.

070816 SBG 1KW-60640-0



敏盛企業有限公司
<http://www.mavin.com.tw>

免責聲明

資料僅供參考，若有與原廠不合之處，請以原廠規格為準，且不供任何證明文件之用

TEL:03-5970828 FAX:03-5972622 新竹湖口工業區工業四路3號2F

