



**P7700 Series
TriMode™ Probes
Technical Reference**



077-1124



敏盛企業有限公司

<http://www.mavin.com.tw>

免責聲明

資料僅供參考，若有與原廠不合之處，請以原廠規格為準，且不供任何證明文件之用

TEL:03-5970828 FAX:03-5972622 新竹湖口工業區工業四路3號2F



**P7700 Series
TriMode™ Probes
Technical Reference**

www.tek.com

077-1124-01

 **敏盛企業有限公司**
<http://www.mavin.com.tw>

免責聲明

資料僅供參考，若有與原廠不合之處，請以原廠規格為準，且不供任何證明文件之用

TEL:03-5970828 FAX:03-5972622 新竹湖口工業區工業四路3號2F

Copyright © Tektronix. All rights reserved. Licensed software products are owned by Tektronix or its subsidiaries or suppliers, and are protected by national copyright laws and international treaty provisions.

Tektronix products are covered by U.S. and foreign patents, issued and pending. Information in this publication supersedes that in all previously published material. Specifications and price change privileges reserved.

TEKTRONIX and TEK are registered trademarks of Tektronix, Inc.

TriMode and TekFlex are trademarks of Tektronix, Inc.

Contacting Tektronix

Tektronix, Inc.
14150 SW Karl Braun Drive
P.O. Box 500
Beaverton, OR 97077
USA

For product information, sales, service, and technical support:

- In North America, call 1-800-833-9200.
- Worldwide, visit www.tek.com to find contacts in your area.

Warranty

Tektronix warrants that this product will be free from defects in materials and workmanship for a period of one (1) year from the date of shipment. If any such product proves defective during this warranty period, Tektronix, at its option, either will repair the defective product without charge for parts and labor, or will provide a replacement in exchange for the defective product. Parts, modules and replacement products used by Tektronix for warranty work may be new or reconditioned to like new performance. All replaced parts, modules and products become the property of Tektronix.

In order to obtain service under this warranty, Customer must notify Tektronix of the defect before the expiration of the warranty period and make suitable arrangements for the performance of service. Customer shall be responsible for packaging and shipping the defective product to the service center designated by Tektronix, with shipping charges prepaid. Tektronix shall pay for the return of the product to Customer if the shipment is to a location within the country in which the Tektronix service center is located. Customer shall be responsible for paying all shipping charges, duties, taxes, and any other charges for products returned to any other locations.

This warranty shall not apply to any defect, failure or damage caused by improper use or improper or inadequate maintenance and care. Tektronix shall not be obligated to furnish service under this warranty a) to repair damage resulting from attempts by personnel other than Tektronix representatives to install, repair or service the product; b) to repair damage resulting from improper use or connection to incompatible equipment; c) to repair any damage or malfunction caused by the use of non-Tektronix supplies; or d) to service a product that has been modified or integrated with other products when the effect of such modification or integration increases the time or difficulty of servicing the product.

THIS WARRANTY IS GIVEN BY TEKTRONIX WITH RESPECT TO THE PRODUCT IN LIEU OF ANY OTHER WARRANTIES, EXPRESS OR IMPLIED. TEKTRONIX AND ITS VENDORS DISCLAIM ANY IMPLIED WARRANTIES OF MERCHANTABILITY OR FITNESS FOR A PARTICULAR PURPOSE. TEKTRONIX' RESPONSIBILITY TO REPAIR OR REPLACE DEFECTIVE PRODUCTS IS THE SOLE AND EXCLUSIVE REMEDY PROVIDED TO THE CUSTOMER FOR BREACH OF THIS WARRANTY. TEKTRONIX AND ITS VENDORS WILL NOT BE LIABLE FOR ANY INDIRECT, SPECIAL, INCIDENTAL, OR CONSEQUENTIAL DAMAGES IRRESPECTIVE OF WHETHER TEKTRONIX OR THE VENDOR HAS ADVANCE NOTICE OF THE POSSIBILITY OF SUCH DAMAGES.

[W2 – 15AUG04]

Table of Contents

Important safety information	iv
General safety summary	iv
Terms in this manual	v
Symbols and terms on the product	v
Theory of operation	1
Introduction	1
TriMode operation	10
Operating voltages	12
Improving measurement accuracy	21
Reference	31
Single-ended measurements	31
Differential measurements	32
Specifications	37
Warranted characteristics	37
Typical characteristics	40
Host instrument firmware	47
Index	



List of Figures

Figure 1: P7700 Series TriMode probe components	1
Figure 2: P7700 Series TriMode active probe tips.....	4
Figure 3: P7700 Series TriMode probe input architecture	5
Figure 4: TriMode input structure	11
Figure 5: P7700 probe tip inputs.....	12
Figure 6: Operating voltage window (TekFlex solder-in tips).....	13
Figure 7: Dynamic range versus linearity at the probe amplifier step gain settings.....	15
Figure 8: Operating voltage window (P77BRWSR).....	16
Figure 9: Dynamic range linearity error plot.....	16
Figure 10: Simplified diagram of the P7700 Series probe tip input network	18
Figure 11: Probe setup screen	19
Figure 12: Simplified Auto Offset circuitry	20
Figure 13: P77STFLXA solder tip attached with 10 mils (0.250 mm) wires (rise time = 30.5 ps)	23
Figure 14: P77STFLXA solder tip attached with 75 mils (1.90 mm) wires (rise time = 27.9 ps).....	23
Figure 15: P77STFLXA solder tip attached with 120 mils (3.05 mm) wires (rise time = 30.1 ps)	24
Figure 16: P77STFLXA solder tip attached with 200 mils (5.08 mm) wires (rise time = 34 ps).....	24
Figure 17: P77STFLXA solder tip attached with 300 mils (7.62 mm) wires (rise time = 42.8 ps)	25
Figure 18: Simplified diagram of the P7700 Series probe tip input network	26
Figure 19: Differential input mode signal voltage and offset voltage	28
Figure 20: Solder tip measurement configuration.....	29
Figure 21: Example of LVDS differential signal.....	29
Figure 22: Simplified model of a differential amplifier	33
Figure 23: Typical CMRR.....	34
Figure 24: Typical channel isolation	36
Figure 25: P77STCABL differential impedance.....	43
Figure 26: P77STCABL SE impedance	43
Figure 27: P77STFLXA differential impedance	44
Figure 28: PST77FLXA SE impedance.....	44
Figure 29: P77BRWSR differential impedance.....	45
Figure 30: Differential mode P77STCABL and P77FLXA equivalent circuit diagram.....	45
Figure 31: Single-ended P77FLXA equivalent circuit diagram.....	45
Figure 32: P77BRWSR equivalent circuit diagram with 50 mil spacing.....	46
Figure 33: P77BRWSR equivalent circuit diagram with 200 mil spacing	46

List of Tables

Table 1: Probe tip attenuation factors	6
Table 2: Rise time and overshoot degradation versus lead length	25
Table 3: Single-ended dynamic and offset ranges	31
Table 4: Electrical characteristics.....	37
Table 5: Environmental characteristics	39
Table 6: Typical electrical characteristics.....	40
Table 7: Electromagnetic compatibility (EMC)	42



Important safety information

This manual contains information and warnings that must be followed by the user for safe operation and to keep the product in a safe condition.

General safety summary

Use the product only as specified. Review the following safety precautions to avoid injury and prevent damage to this product or any products connected to it. Carefully read all instructions. Retain these instructions for future reference.

This product is not intended for detection of hazardous voltages.

To avoid fire or personal injury

Observe all terminal ratings. To avoid fire or shock hazard, observe all ratings and markings on the product. Consult the product manual for further ratings information before making connections to the product.

Do not apply a potential to any terminal, including the common terminal, that exceeds the maximum rating of that terminal.

Do not operate without covers. Do not operate this product with covers or panels removed, or with the case open. Hazardous voltage exposure is possible.

Avoid exposed circuitry. Do not touch exposed connections and components when power is present.

Do not operate in wet/damp conditions. Be aware that condensation may occur if a unit is moved from a cold to a warm environment.

Do not operate in an explosive atmosphere.

Keep product surfaces clean and dry. Remove the input signals before you clean the product.

Probes and test leads

Remove all probes, test leads and accessories that are not in use.

Inspect the probe and accessories. Before each use, inspect probe and accessories for damage (cuts, tears, or defects in the probe body, accessories, or cable jacket). Do not use if damaged.

Use only the specified replacement parts.

Terms in this manual

These terms may appear in this manual:



WARNING. *Warning statements identify conditions or practices that could result in injury or loss of life.*



CAUTION. *Caution statements identify conditions or practices that could result in damage to this product or other property.*

Symbols and terms on the product

These terms may appear on the product:

- DANGER indicates an injury hazard immediately accessible as you read the marking.
- WARNING indicates an injury hazard not immediately accessible as you read the marking.
- CAUTION indicates a hazard to property including the product.



When this symbol is marked on the product, be sure to consult the manual to find out the nature of the potential hazards and any actions which have to be taken to avoid them. (This symbol may also be used to refer the user to ratings in the manual.)

The following symbol(s) may appear on the product:



CAUTION
Refer to Manual



Theory of operation

Introduction

The P7700 Series TriMode Probes are designed for use with MSO/DPO70000C and newer oscilloscopes. Four P7700 Series TriMode Probe models are available with bandwidths from 8 GHz to 20 GHz. MSO/DPO70000C oscilloscope models are available at comparable bandwidths. These probe and oscilloscope models feature the high performance TekConnect intelligent probe interface. P7700 Series probes must be operated with an attached P7700 Series probe tip. Several P7700 Series probe tip models are available to support different application requirements.

The P7700 Series probes and probe tips contain device-specific S-parameter data that, when transferred to the host oscilloscope after the initial connection is made, create unique system DSP filters. These DSP filters optimize high frequency performance of the probe and probe tip signal path.

The P7700 Series probes are optimized for high bandwidth; they are not general-purpose probes. The P7700 Series probe solder tips that can be used with the probes are miniaturized for electrical characteristics and access to dense circuitry, and must be handled carefully.

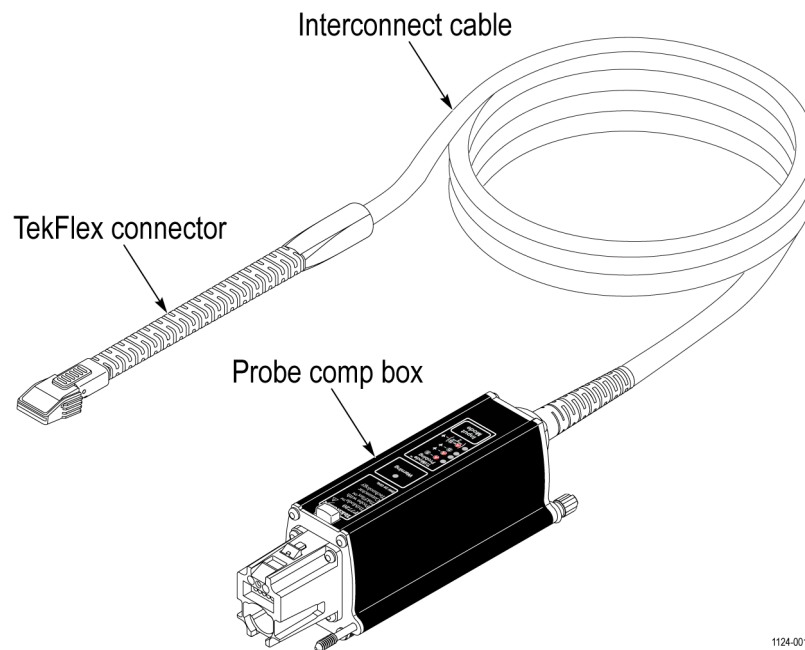

Figure 1: P7700 Series TriMode probe components

Probe components P7700 Series probes are comprised of a probe compensation box (comp box), a TekFlex connector for attaching probe tips, and an interconnect cable that transfers measured signals, power, and control signals between the probe comp box and the TekFlex connector probe head. A P7700 Series probe tip must be inserted into the TekFlex connector probe head to make the final connection to the DUT (device under test).

Probe compensation box. The probe compensation box assembly mates to the host instrument through an intelligent TekConnect probe interface. Power, control signals, and the signal measured by the probe are transferred to and from the oscilloscope through the TekConnect interface. The comp box includes a membrane toggle switch to select the TriMode input mode for probe tips that support TriMode functionality:

- Differential (A–B)
- A input (single-ended to ground)
- B input (single-ended to ground)
- Common-mode ((A+B)/2 to ground)

The probe input mode can also be selected using the oscilloscope probe controls or Probe Setup menu. The Probe Setup menu is also used to adjust the probe Offset A and Offset B voltage settings and to initiate a DC Probe Compensation operation. All other P7700 Series probe internal controls are handled automatically through communication between the probe and oscilloscope.

An LED on the top panel of the comp box indicates the selected input mode. Another LED indicates when a warning condition exists. Warnings are caused when parameters such as input voltages exceed the safe limits of the probe.

A mechanical latch and optional retention thumbscrew hold the probe securely to the instrument during use. The thumbscrew is only intended to be finger-tightened, and is machined to prevent tools from being used to over-torque it. To remove the probe, loosen the thumbscrew counterclockwise, depress the latch button to release the probe, and then pull out the probe.



CAUTION. *To prevent damage to the probe, use care when handling the probe. Rough or careless use can damage the probe.*

Main interconnect cable. This cable assembly consists of a pair of matched, low-loss coaxial signal cables that carry the acquired signal from the probe head to the probe comp box. The cable assembly includes an 8-conductor bundle of wires that supply probe tip head power and control signals from the probe comp box through the TekFlex connector interface. Some of the wires carry bidirectional data, such as queries and responses about the type of probe tip attached to the TekFlex connector, and other probe tip-specific information.

TekFlex™ connector. The new TekFlex connector technology combines a high speed signal path with low speed control signaling in a single, easy to connect accessory connector. The TekFlex connector has a pinch-to-open design that when open requires minimal force to attach an accessory tip. When the TekFlex connector is closed, it provides a secure connection to the accessory to avoid accidental disconnections.

The connector provides a light-weight electrical and mechanical interface between a P7700 Series probe and a P7700 Series active probe tip. It contains a spring-loaded set of electrical contacts that connect between the main cable wiring and contact patterns on the attached probe tip. There is a differential, high-frequency contact pattern on the top of the probe tip that connects the probe tip dual signal inputs and grounds to the probe main cable coaxial pair. There is also an eight-finger contact pattern on the bottom of the probe tip that connects the probe tip power and control signals to a ribbon wire in the main cable. The TekFlex connector provides mechanical alignment between a keyed hole pattern on the probe tip and a pair of pins inside the spring loaded connector housing.

With the TekFlex connector, the P7700 series probes offer a set of active probe tips with the probe's buffer amplifier only millimeters from the input connections. The short signal path enabled with the active tips provides high fidelity and a high impedance input. It minimizes signal loss, capacitance, and additive noise.



Probe tips. The probe tips are automatically detected and displayed in the Probe Setup screen.

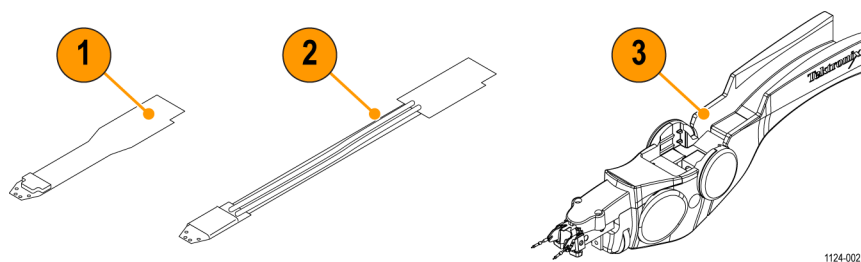

Figure 2: P7700 Series TriMode active probe tips

1. TekFlex solder-in tips. These tips use flex circuit material and provide soldered, multi-point connections. They support full TriMode measurement capabilities and full probe bandwidth. If care is taken during the soldering process, these probe tips can be reused through multiple soldering operations. The small size and low cost design are good for high interconnect density measurements.

The first time the probe tip is detected, S-parameter data for the probe tip is sent to the oscilloscope, and probe-tip specific DSP filters are generated. These filters improve the measurement accuracy of high-frequency measurements.

2. P77STCABL. This optional tip provides a soldered, multi-point connection that supports full TriMode measurement capabilities at full probe bandwidth. If care is taken during the soldering process, this probe tip can be reused through multiple soldering operations. In some applications the robust mechanical design of the tip and flexible cable construction provides better usability, compared to the lower cost flex circuit tips. The first time the probe tip is detected, S-parameter data for the probe tip is sent to the oscilloscope, and probe-tip specific DSP filters are generated.
3. P77BRWSR. The optional browser connects to the circuit using two input contacts with very fine point tips. These tips have built-in compliance 0.02 in (0.5 mm) and adjustable spacing 0.008 in to 0.210 in (0.2 mm – 5.3 mm). The input contacts include an embedded damping resistor for optimum measurement performance.

The browser tip can be held in place or can be used to make hands-free connections to the DUT when using the Browser Tri-Pod accessory, or a probe positioner, such as the Tektronix PPM203B. The browser includes multiple sets of S-parameters based on the spacing of the tips. The spacing is monitored and the correct set of S-parameters are automatically used.

Probe input architecture

P7700 Series probes feature a new probe architecture that addresses the need for high frequency response with decreased probe loading for high-speed, low power applications such as MIPI® and LPDDR. High performance probes with multi-GHz bandwidth have evolved in recent years, starting from traditional designs with metal pin tips attached to a probe head amplifier located at the end of a coaxial cable. As the probe bandwidth extended to 10 GHz and above, probe designs migrated to connectorized amplifier input structures that supported a variety of high frequency passive probe tips, including solderable tip designs. These probe tips typically provide a passive input attenuator network at the probe tip followed by a long cable attached to the probe amplifier connection socket. Although these passive tip, probe designs enable good, high frequency performance, they show higher probe loading in the frequency band below 1 GHz than earlier traditional designs with an amplifier closer to the probe tip. A probe with this higher loading characteristic below 1 GHz has problems when taking measurements of signals such as MIPI that can be switched to an unterminated, high impedance mode for low power operation. The P7700 Series probe solves this loading problem by introducing an active probe tip design with a tiny buffer amplifier located near the tip inputs. By locating an amplifier with a high impedance attenuator network at the probe tip inputs, the probe tip parasitic capacitance can be kept much lower than passive cable tip designs, thus reducing probe loading in the low power signaling frequency band used by serial data standards such as MIPI.

The following figure shows a simplified diagram of the P7700 Series active probe tip architecture.

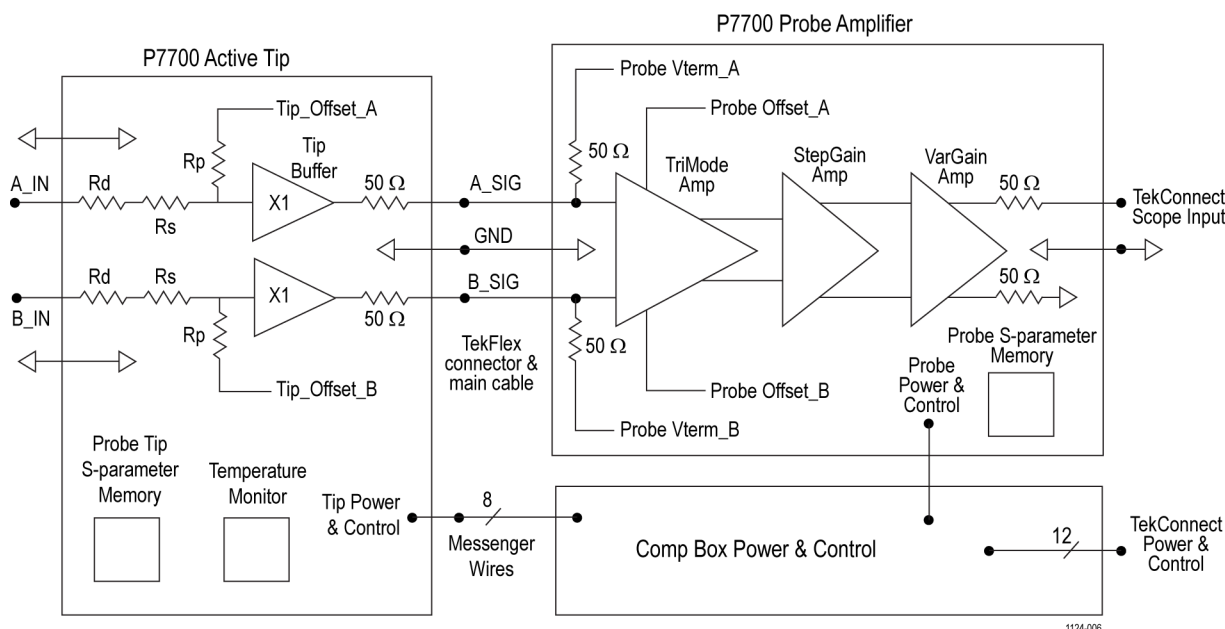

Figure 3: P7700 Series TriMode probe input architecture

The P7700 Series active probe tip has two inputs, A_IN and B_IN, which can, depending on the tip design, support TriMode measurements. With a TriMode tip, such as a TekFlex solder-in tip, it is possible to make differential, single-ended A, single-ended B, and common-mode measurements, all from a single soldered differential signal connection to a DUT. The soldered wire connections between the two probe tip input signal vias and DUT differential signal nodes should be kept as short as possible (as should the ground via connections if single-ended measurements will be made). The A and B input signals on the probe tip pass to a matched pair of damping resistors, R_d , that isolate the probe connection to the DUT. The damping resistor value of approximately $100\ \Omega$ also serves to tune the probe tip high frequency response. Following each input damping resistor is a pair of attenuation resistors, R_s and R_p . The attenuation resistor values depend on the specific probe tip attenuation factor design. There are currently two attenuation factors available as shown in the following table with approximate attenuation resistor values. The probe tip attenuation factor in the table includes an additional 2X factor due to attenuation from the $50\ \Omega$ tip buffer output impedance and the $50\ \Omega$ probe amplifier termination impedance.

Table 1: Probe tip attenuation factors

Attenuation factor	R_s	R_p	Dynamic range	Offset voltage range
4x	25 k Ω	25 k Ω	2.5 V _{pp}	$\pm 4.0\ \text{V}$
10x	60 k Ω	15 k Ω	6.0 V _{pp}	$\pm 10.0\ \text{V}$

The input attenuation resistors serve three major functions for the dual input tip buffer:

- The high resistance of the attenuation resistors provides very light loading on the probe input signals.
- The probe tip attenuation factor expands the linear dynamic range of the probe tip inputs.
- The probe tip attenuation network provides a resistive summing junction for injecting an offset voltage signal to extend the probe tip operating voltage window.

The P7700 Series active tips contain a pair of unity gain amplifiers that buffer the DUT differential input signal. These buffer amplifiers provide an impedance conversion for the input signals from the high impedance input attenuator at the tip input to the $50\ \Omega$ output drive at the tip output. The buffer amplifier $50\ \Omega$ output impedance is needed to drive the probe TekFlex connector and meter-long main cable transmission lines with good high frequency fidelity. The new TekFlex interface to which the P7700 Series probe tips are attached includes both a dual high frequency connection for the probe tip signals as well as a low frequency connection for eight messenger wires that provide power and control for the active probe tips.

The control features of the new TekFlex interface include two analog tip offset voltage signals, a pair of digital communication signals for accessing the probe tip S-parameter memory, and a probe tip temperature monitor signal.

The probe tip S-parameter memory contains characterization data for use with DSP correction filters that are unique to the probe tip. The S-parameter memory includes a unique data header used in automatically identifying the probe tip type and serial number. The A and B signal outputs from the probe tip are connected by high frequency spring contacts in the TekFlex connector to a pair of delay-matched coaxial cables that carry the input signals through the main cable and into the comp box. These signals terminate to a pair of 50 Ω termination resistors at the probe amplifier in the comp box. The termination resistors have an adjustable termination voltage connection for optimal loading of the probe tip output signals. The TekFlex interface messenger wires are routed as a small gauge ribbon cable, along with the delay-matched coaxial cables, inside a shielded main cable assembly.

The P7700 Series probe amplifier has several cascaded amplifier stages that condition the probe tip differential signal for precision measurement fidelity. The complex input stage of the probe amplifier selects the desired TriMode input mode.

This input stage of the probe amplifier includes connections for injecting a pair of adjustable probe offset voltages for precision control of the probe output zero voltage, which is a measure of the output signal with zero volts at both probe tip inputs.

The next stage in the probe amplifier is the step gain stage. The step gain stage provides several switchable, coarse gain steps, that extend the sensitivity range of the probe measurement down to the millivolt level with good noise performance. The step gain stage is automatically switched to its optimum setting by the oscilloscope as the oscilloscope vertical channel sensitivity is adjusted by the user.

The final stage of the probe amplifier is the variable gain stage. The variable gain stage is used for fine tune adjustment of the gain of the probe and probe tip to its calibrated value. The calibrated gain setting is determined from calibration constants characterized during manufacturing testing of the probe and probe tip and includes compensation for probe temperature variation. Although the signal that passes through the probe amplifier is processed as a differential signal through the internal amplifier stages, it is routed to the oscilloscope's TekConnect interface as a single-ended output.

The ground path for high frequency signal return currents is shown in the probe architecture figure. (See Figure 3 on page 5.) The probe ground path is continuous and along the following path:

- Extends from the DUT ground vias connections at the probe tip input
- Through the probe tip ground path
- Through the TekFlex connector ground spring contacts
- Along the main cable coaxial shields into the probe comp box
- Through the probe amplifier circuit board ground plane inside the probe comp box, and
- Through the TekConnect interface to the host oscilloscope ground

A TriMode tip requires a short DUT ground reference for making low noise single-ended probe measurements.

Although two ground via connections are available on the probe tip input, a single ground via wire connection is usually adequate for making single-ended measurements of both the A and B input signals or a common-mode measurement, all of which are ground referenced.

If only one single ended signal will be connected to the probe, the user has the choice of connecting the A input to the signal and the B input to ground, or connecting the A input to the signal and the ground input of the probe to the ground input of the DUT. In this situation, Tektronix recommends using A-B mode with the B input connected to ground. Reasons for this recommendation include that with the B input left disconnected, there is a possibility of an interfering signal coupling into the input of the probe and distorting the measured signal acquired on the A side.

A second reason for using A-B vs. A-ground is that it is often more convenient to connect the differential inputs of the probe to a device and keep the wire lengths short. The ground connections of the probe are set back from the tip and may not be as convenient to connect to a DUT with tightly spaced test points.

The optional accessory P77BRWSR is a variable-spacing probe tip which operates in Differential Input mode only. The P77BRWSR Browser probe tip does not have a physical ground connection at the probe tip; but the differential measurement process itself provides a high frequency virtual ground connection between the A and B signal input pins. A low frequency ground connection is optionally available at a square-pin socket on the browser probe tip housing.

The comp box receives power and control signals from the oscilloscope through the TekConnect interface. The TekConnect interface is an intelligent probe connection that includes many automated and manual control features. For example, there is a probe S-parameter memory in the comp box that stores high frequency characterization data for the probe signal path.

The downloaded S-parameter data for a probe and attached probe tip is used by the oscilloscope to generate a DSP correction filter for optimum measurement fidelity. Because this S-parameter data is unique and serialized for each probe and probe tip, it only needs to be downloaded once to an oscilloscope.

Automatic probe tip type identification is another example of the intelligent operation of the P7700 Series probes. When no probe tip is attached to the TekFlex connector of a P7700 Series probe, the TekFlex probe tip interface power is disabled. When a probe tip is attached to the TekFlex connector, the attachment is detected by the probe and the probe queries the probe tip memory to check for a valid identification header. If a valid probe tip type is verified by this TekFlex data interface query, the probe tip power is enabled until the probe tip detachment is detected.

When probe tip power is enabled, an LED is activated on the probe tip, indicating that the TekFlex interface and attached probe tip appear to be operating properly. If the probe tip type attached to the TekFlex connector is a browser probe tip, the probe tip automatically detects the current tip spacing and communicates that information to the oscilloscope.

There are several calibrated tip spacing regions defined for the browser tip, which affect the frequency response of the browser tip signal. Wider tip spacing tends to degrade the browser tip frequency response. The oscilloscope uses the current tip spacing region information to select the optimum DSP correction filter for use with the browser tip measurements.

TriMode operation

The TriMode feature of the P7700 Series probes is designed for improved convenience and enhanced capability in measuring differential signal quality. Because a differential signal is composed of two complementary single-ended signals, full characterization of a differential signal requires more than a simple differential measurement.

A TriMode probe features four input modes that allow a differential signal to be fully characterized with four measurements:

- Differential
- Positive polarity, single-ended
- Negative polarity, single-ended
- Common mode

A TriMode probe provides improved efficiency and convenience by enabling full differential signal characterization from a single soldered connection.

P7700 Series active probe solder tips support the TriMode functionality of a P7700 Series probe by buffering a matched pair of input signals from a DUT differential signal connection. These active solder tips support the transmission of high-frequency return currents through a probe tip ground path referenced to the DUT ground connection.

Using any of the P7700 solder-in tips, probe connections are made to the two complementary signals (the A signal and the B signal) and a ground reference. From this single DUT connection, the internal electronic switching control of the TriMode probe allows any one of the four probe input modes to be selected at a time. The TriMode probe inputs are routed to an ASIC (application-specific integrated circuit) inside the probe to a set of four independent input amplifiers that perform the following signal calculations:

- $A - B$ (for differential signal measurement)
- $A - \text{GND}$ (for A input single-ended measurement)
- $B - \text{GND}$ (for B input single-ended measurement)
- $[A+B]/2 - \text{GND}$ (for common mode measurement)

NOTE. *In the B – GND Mode, the negative polarity B input is not inverted.*

The four input amplifiers are multiplexed together and only the selected input mode function is sent to the connected oscilloscope. The following figure shows a conceptual view of the TriMode probe input structure, where the C input provides the probe ground reference and is connected to the probe tip ground interconnect using the probe's cable coaxial shields.

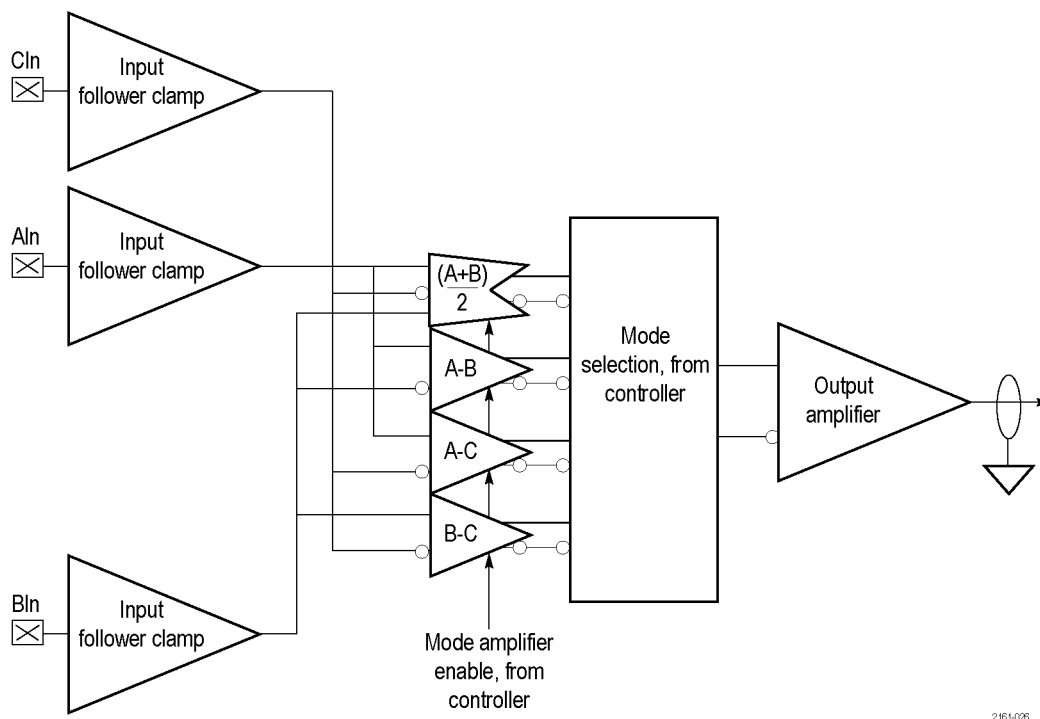

Figure 4: TriMode input structure

For oscilloscopes that provide full TriMode support, the oscilloscope-controlled probe graphical-user interface can perform a probe compensation operation on all input modes and attenuation settings at once using the Probe DC Calibration fixture supplied with each P7700 Series probe.

Operating voltages

The P7700 Series probes are designed to probe high-frequency, low-voltage circuits. Before probing a circuit, take into account the limits for the operating voltages discussed in this section.

- Input voltage
- Operating voltage window
- Input signal dynamic range
- Offset voltage

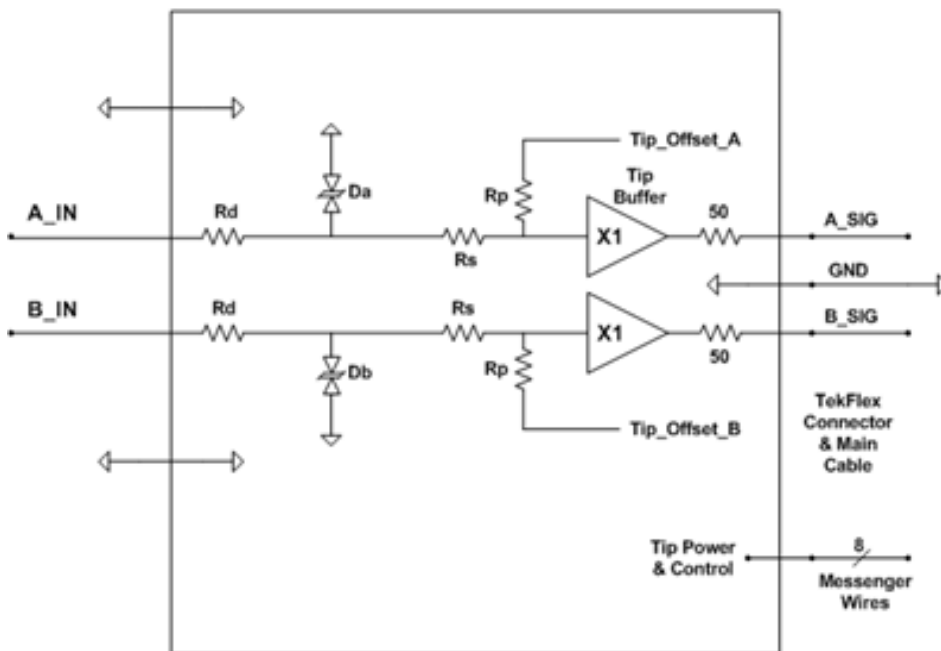

Figure 5: P7700 probe tip inputs

Input voltage The maximum input voltage is the maximum voltage to ground that the inputs can withstand without damaging the probe input circuitry. The P7700 Series active probe tips include some over-voltage protection circuitry at the probe tip signal inputs. (See Figure 5.) Transient voltage suppression diodes, Da and Db, provide bidirectional voltage clamping of signals applied to the probe tip inputs. These TVS diodes limit potential ESD damage as well as signal over-voltage damage to the active tip buffer amplifier device.

CAUTION. To avoid damaging the inputs of the probe, do not apply more than $\pm 15\text{ V}$ (DC + peak AC) between either probe input and ground.

CAUTION. To avoid ESD damage to the probe, always use an antistatic wrist strap (provided with your probe), and work at a static-approved workstation when handling the probe.

Operating voltage window The operating voltage window defines the input signal voltage range within which probe measurements can be made with good fidelity. The operating voltage window limits for the TekFlex solder-in tips are shown as the larger gray square in the following figure.

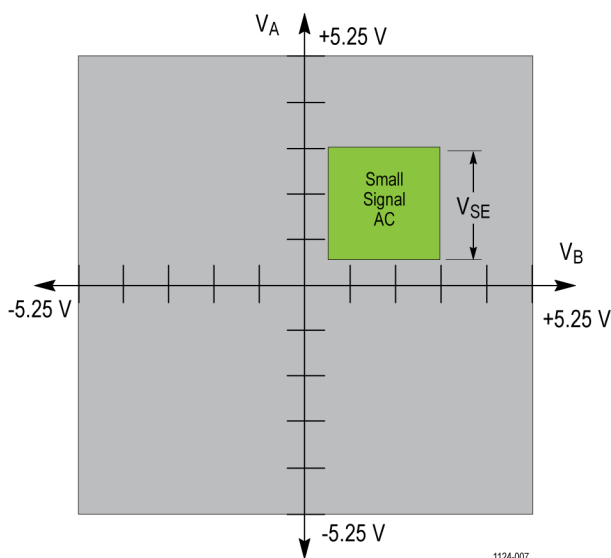

Figure 6: Operating voltage window (TekFlex solder-in tips)

The A operating voltage window range of $\pm 5.25\text{ V}$ is shown on the vertical axis and the B operating voltage window range of $\pm 5.25\text{ V}$ is shown on the horizontal axis. The dynamic range is also shown on the figure as the smaller green square. The P7700 solder tip single-ended dynamic range for both the A and B inputs is $2.5\text{ V}_{\text{p-p}}$. Differentially, the solder tip dynamic range is $5\text{ V}_{\text{p-p}}$.

The dynamic range square (labeled *Small Signal AC* in the previous figure) can be moved around within the limits of the operating voltage window by adjusting the A and B offset voltage settings. The A and B offset voltage values determine the location of the center of the dynamic range square in the operating voltage window plot. The A and B offset voltages are both set to +1.75 V in the previous figure.

With these offset voltage settings, the probe tip linear measurement range is from +0.5 V to +3.0 V for both the A and B tip inputs. Input voltages outside these dynamic range limits will begin to compress and lead to measurement signal distortion. Because the offset voltage range for the P7700 solder tips is ± 4.0 V, the smaller dynamic range square can be moved anywhere within the larger operating voltage window.

Because there are several step gain values available within the P7700 Series Probe Amplifier, the actual size of the dynamic range square depends upon the oscilloscope vertical scale factor setting. The vertical scale factor determines the required probe amplifier step gain setting, which is automatically set to the proper value under the oscilloscope control.

The dynamic range square is set to its full-size $2.5 V_{p-p}$ setting when the vertical scale factor is set to large enough V/div settings that a $2.5 V_{p-p}$ signal can be fully displayed on the oscilloscope. As the vertical scale factor is set to lower V/div settings, the probe amplifier step gain threshold will eventually be reached and the step gain value will be increased by one step.

Increasing the step gain by the nominal 2X factor decreases the size of the dynamic range by half, which results in a decrease in the area of the dynamic range square by a 4X factor. The decrease in linear dynamic range at different step gain settings can be seen in the linearity plot in the following figure.

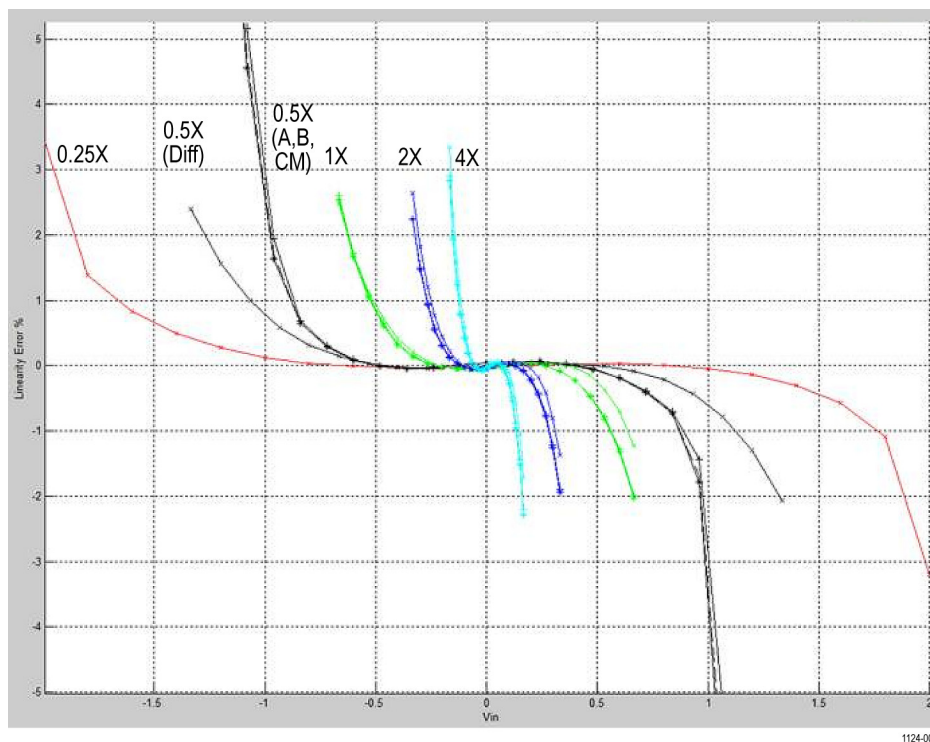

Figure 7: Dynamic range versus linearity at the probe amplifier step gain settings

The size of the operating voltage window and the size of the full dynamic range for a P7700 Series probe tip depend on the attenuation factor of the input attenuation network at the probe tip. A larger attenuation factor usually results in a larger operating voltage window and a larger full-size dynamic range square as shown for the P77BRWSR probe tip in the following figure.

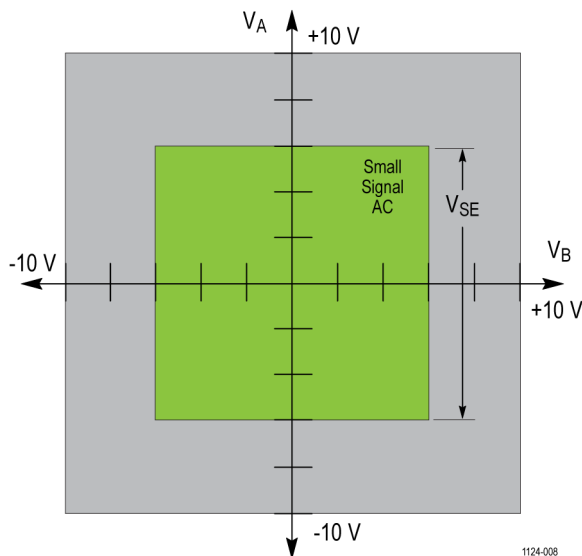

Figure 8: Operating voltage window (P77BRWSR)

Input signal dynamic range

The input signal dynamic range is the maximum voltage difference between the A and B inputs of the probe tip and the probe tip ground reference that the probe can accept without distorting the signal. The distortion from a voltage that exceeds this maximum can result in a clipped or otherwise inaccurate measurement. The following figure shows the typical linearity error over the dynamic voltage range of a probe solder tip for the A and B tip inputs.

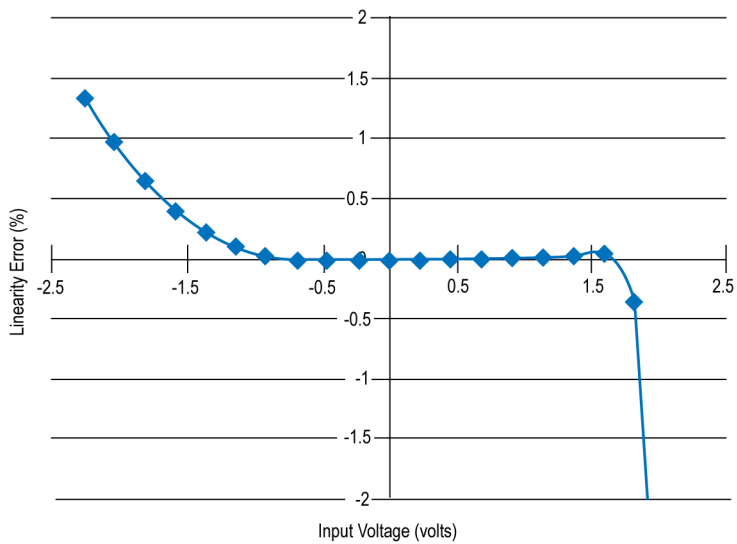

Figure 9: Dynamic range linearity error plot

The dynamic range of P7700 Series probe tips is specified with a linearity error limit of $\pm 1\%$. As shown in the Linearity Error plot, the linearity error increases as the input voltage increases above the dynamic range limit for both signal polarities. The dynamic range is not a hard limit for signal distortion; probe tip input voltages can slightly exceed the dynamic range limit if a slightly higher linearity error is determined to be acceptable.

The dynamic range for P7700 Series probe tips is also specified as a maximum peak-to-peak voltage. With the probe tip A and B offset voltages both set to 0 V, the dynamic range will be symmetrical around that 0 V level. In this case, the dynamic range can be considered to equal $\pm(\text{dynamic range} \div 2)$. If the oscilloscope vertical scale factor is set high enough to display the full dynamic range, the oscilloscope will momentarily add dynamic range limit annunciation lines. These dynamic range annunciation lines can be refreshed by adjusting one of the vertical channel knobs, such as position or scale factor.

The differential input mode dynamic range is specified to be almost twice as large as the single-ended signal dynamic range; but this is true only for complementary A and B input signals. The single-ended A and B dynamic range limits still apply, even for the case of a maximum differential mode input signal.



Offset voltage

The offset voltage control sums an adjustable DC voltage with the probe signal input. It is commonly used to nullify an input DC bias voltage to center the input signal swing within the linear dynamic range of the probe input. The A and B probe inputs both have an independent offset voltage control. The following figure shows a simplified diagram of a P7700 Series probe tip input network.

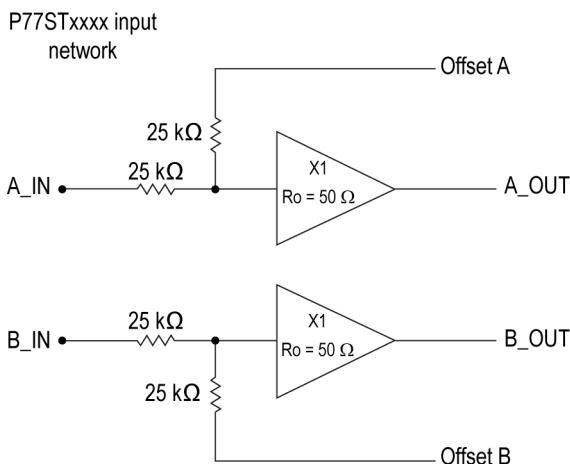

3421-031

Figure 10: Simplified diagram of the P7700 Series probe tip input network

The offset voltage affects the probe tip buffer's measured signal through a resistive summer configuration that forms the buffer's input attenuator network. The high value resistors used in the input attenuator result in an interaction between the input signal and the offset voltage DC level.

Calibrated offset voltage performance requires both the input signal and the offset voltage generator in the probe have a source resistance that is very small compared to the 25 kΩ attenuator resistors. The source resistance (R_s) of the offset voltage generator in the probe is less than 1 Ω and measured DUT signals typically have $R_s \ll 25 \text{ k}\Omega$. If a probe tip is attached to a probe TekFlex connector with its probe tip inputs open, the input signal source resistance is much larger than the 25 kΩ attenuator resistors. As a result, the offset voltage control is no longer calibrated and will have twice the calibrated effect on the measured probe output.

The offset voltage control, accessible from the attached oscilloscope front-panel control and the on-screen user interface, allows the probe dynamic range to be effectively moved up and down within the limits of the offset voltage range and the operating voltage window. When the offset voltage is set to zero volts and the input signal is zero volts (inputs shorted to ground, not open), the displayed signal should be zero volts. If a noticeable zero volt offset is present under the above conditions, a probe compensation operation should be performed.

Offset voltages can be automatically generated by the probe and can be selected using the Auto Offset button in the Offset section of the Probe Setup screen. You can also enter specific offset values directly in the offset fields.

There are four manual offset voltage value entry fields which also display the current offset voltage settings. Although all four offset voltage value entry fields are active, only two of the control pairs are independent.

The manual controls interact with each other as follows:

- Adjusting the A or B settings affects the Differential and Common settings:
 - Differential = $(A - B)$
 - Common = $(A + B)/2$
- Adjusting the Differential or Common settings affects the A and B settings:
 - $A = \text{Common} + (\text{Differential}/2)$
 - $B = \text{Common} - (\text{Differential}/2)$

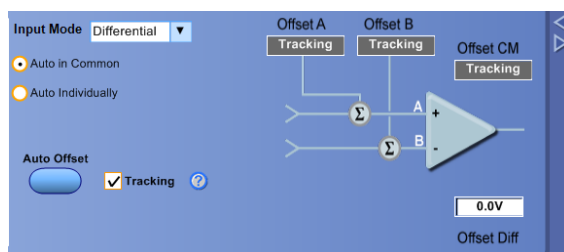

Figure 11: Probe setup screen

There are two Auto Offset modes that can be selected with a radio button selection: Auto in Common or Auto Individually. Both modes operate by sensing the average value of the common-mode voltage on the A and B input signals. When the Auto in common mode is selected and the Auto Offset button is pushed, the A and B offset values are both set to the mean value between the sensed A and B input signal levels. When the Auto Individually mode is selected and the Auto Offset button is pushed, the A offset value is set to the average value of the sensed A input signal level and the B offset value is set to the average value of the sensed B input signal level.

The probe A and B signal inputs are sensed, monitored, and averaged by probe internal circuitry and the sensed values are used to automatically set the Offset Voltage. The Auto Offset circuitry is shown in simplified form in the figure below.

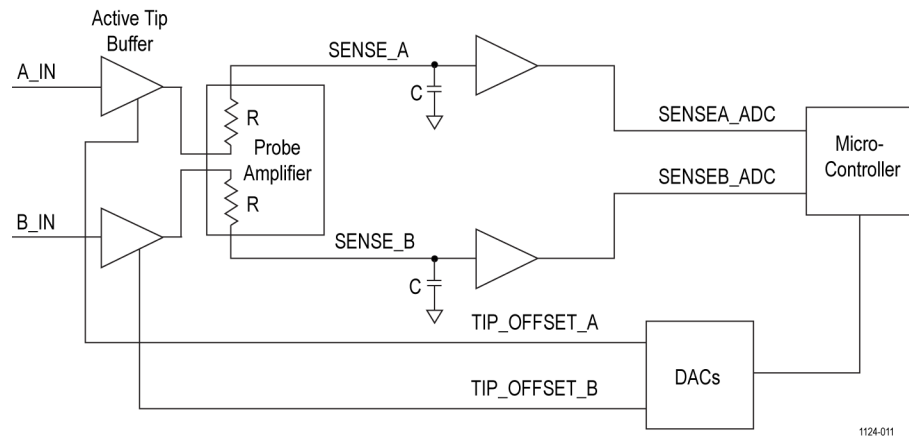

Figure 12: Simplified Auto Offset circuitry

The A and B input signals are buffered by the active probe tip buffer amplifier and passed down the probe main cable assembly into the comp box probe amplifier input pins. The A and B input signals are picked off inside the probe amplifier with large value resistors and output to an averaging filter capacitor as Sense_A and Sense_B signals. These sense signals are buffered by a pair of unity gain amplifiers and passed to the comp box microcontroller ADC conversion inputs. The converted sense signals are transmitted to the oscilloscope when requested by an Auto Offset cycle, where they are processed by the oscilloscope according to the selected Auto Offset mode. The processed mean value or individual A and B offset values are sent back to the probe microcontroller, which drives the tip offset DAC signals accordingly.

Improving measurement accuracy

DSP correction filtering

P7700 Series probes and probe tips use DSP correction filtering to optimize probe measurement fidelity. High frequency time domain measurement performance characteristics such as rise time, aberrations, and pulse flatness are improved by DSP correction filtering. Similarly, frequency domain performance characteristics such as bandwidth, frequency response flatness, and differential signal coupling are improved by DSP correction filtering. DSP correction filtering is performed automatically by the oscilloscope using S-parameter characterization data downloaded from probe and probe tip storage memories. This S-parameter data is unique for each probe and probe tip, rather than the nominal response data that was used in some previous generation probe families.

Distinct S-parameter data sets are stored in probe memory for each probe input mode and step gain setting combination. Every different input mode and step gain combination has a slightly different amplifier signal path, which requires different signal response correction. Since the solder tip buffers do not have complex mode switching, only one S-parameter data set is stored in the probe tip storage memory. The high frequency signal performance of the P77BRWSR browser tip changes slightly as the tip spacing is adjusted. Several S-parameter data sets are stored in the browser tip memory and automatically switched to the optimum data set, under control of the browser tip spacing position detection circuitry.

S-parameter characterization data are measured for each probe and probe tip as part of the manufacturing test process. P7700 Series probe signal performance is measured using a 3-port VNA measurement configuration with a 2-port TekFlex connector input and a 1-port TekConnect interface output. Custom test fixtures have been developed for making VNA port connections to the probe TekFlex connector input and TekConnect interface output. Test fixtures designed for connecting to the probe input and output signal ports are de-embedded to remove interconnect losses and signal path imperfections.

P7700 Series probe tip signal performance is measured using a 4-port VNA measurement configuration with 2-port input and output connections. Because the P7700 Series probe tips do not have standard RF connectors at their inputs or outputs, the custom test fixtures inject and receive VNA port signals. Custom calibration standards were developed to support de-embedding these probe tip manufacturing test fixtures.

DC probe calibration

P7700 Series probes and TekConnect host oscilloscopes support a DC probe calibration process for optimizing probe DC Gain and Output Zero performance. The DC probe calibration operation uses a standard accessory test fixture (Tektronix part number, 067-4889-00) that automates the process. The calibration process uses a programmable DC voltage source available on the oscilloscope front panel. The oscilloscope DC Probe Cal voltage source is connected to and drives a DC Probe Cal test fixture input. The DC Probe Cal test fixture buffers and switches the voltage source signal, as required for the different input modes and step gain settings, to the attached P7700 Series probe tip inputs. The DC Probe Cal voltage source is swept over the probe tip input voltage range as the resulting probe output voltage is measured by the oscilloscope. This combined probe and oscilloscope configuration forms a closed loop measurement system, which is used by the oscilloscope to measure gain and output zero errors. The oscilloscope adjusts its vertical channel gain and offset controls to correct for the measured probe signal errors. The DC probe calibration procedure is described in the *P7700 Series User Manual*.

Solder-in tip connection wire length

There are four via locations for soldering wire connections between the probe tip and the measurement DUT.

The via connections include the probe tip A and B inputs for a differential signal and two ground connections for best performance and flexibility in connecting to a close DUT ground. In general, the probe tip soldered wire connection length should be kept as short as possible. In addition, the probe tip A and B input wires should be matched in length for best differential mode measurement performance.

The differential input mode does not require a ground reference wire connection, since the differential measurement process provides its own virtual ground. The single-ended input modes, which include A-GND mode, B-GND mode, and common mode, all require at least one ground wire connection.

While only connecting the differential inputs of the probe is required and is most convenient, if there is room for another connection and a circuit ground near the probe tip, connecting to a ground connection is recommended. Connecting the ground can help avoid a situation where a large potential on the ground of the DUT causes the test signal to drift outside of the linear range of the input amplifier of the probe. Ideally, it is a good idea to connect the differential inputs and the ground to avoid clipping of the signal in the probe amplifier.

The measurement performance of all input modes is affected by the length of the input wire connection, with high frequency performance degradation increasing with increased wire length.

The measurement performance of the single-ended input modes is affected by the length of the ground wire connection, with high frequency performance degradation also increasing with increased ground wire length. The P7700 Series solder-in probe tip performance is specified using a test fixture built with a probe tip having a signal wire length of 10 mils (.25 mm) and a ground wire length of 66 mils (1.7 mm).

The typical pulse waveforms in the following figures show the effect of input wire length variation on measured responses.

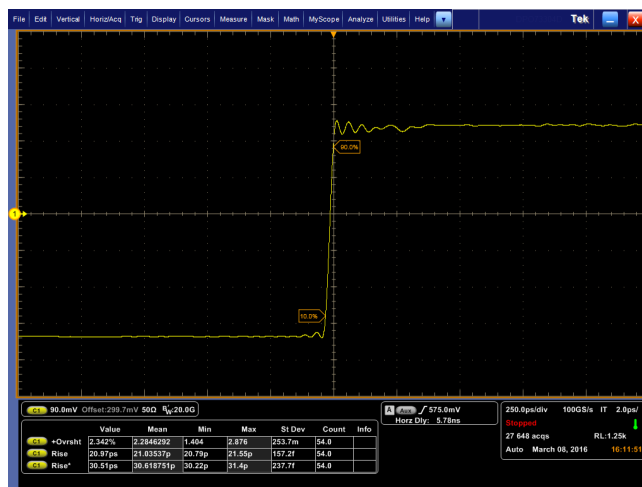

Figure 13: P77STFLXA solder tip attached with 10 mils (0.250 mm) wires (rise time = 30.5 ps)



Figure 14: P77STFLXA solder tip attached with 75 mils (1.90 mm) wires (rise time = 27.9 ps)

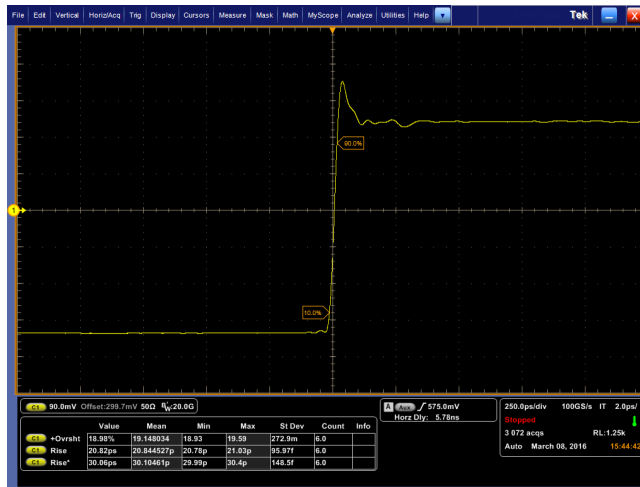

Figure 15: P77STFLXA solder tip attached with 120 mils (3.05 mm) wires (rise time = 30.1 ps)

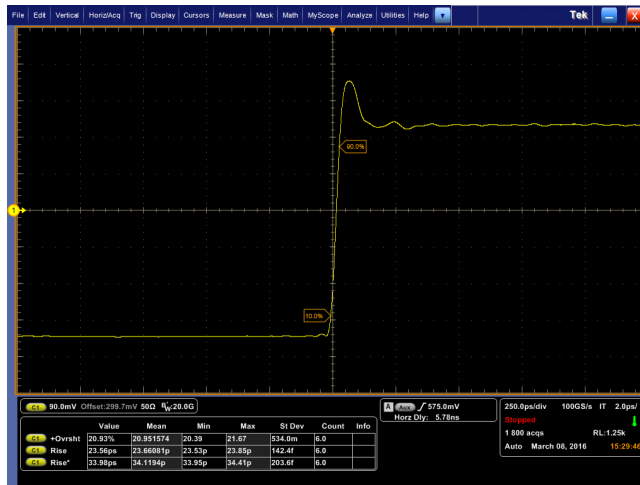

Figure 16: P77STFLXA solder tip attached with 200 mils (5.08 mm) wires (rise time = 34 ps)

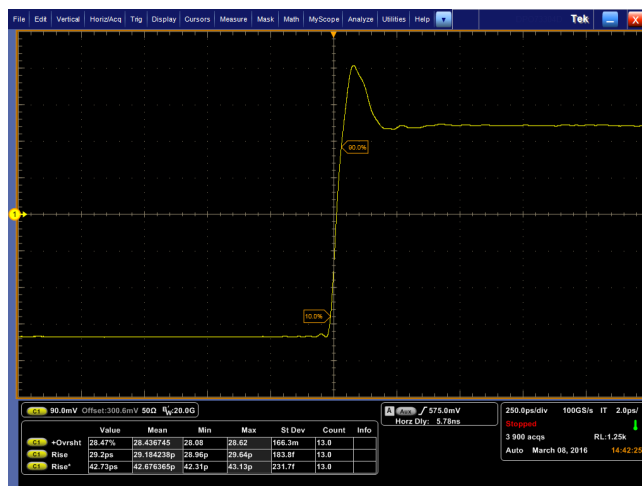

Figure 17: P77STFLXA solder tip attached with 300 mils (7.62 mm) wires (rise time = 42.8 ps)

The following table shows the rise time and overshoot degradation versus lead length.

Table 2: Rise time and overshoot degradation versus lead length

Signal wire lead length	10 - 90 Rise time	20 - 80 Rise time	Effective bandwidth
0.25 mm	30.5 ps	21 ps	20 GHz
1.90 mm	27.9 ps	19.3 ps	20 GHz
3.05 mm	30.1 ps	20.9 ps	20 GHz
5.08 mm	34 ps	23.6	17 GHz
7.62 mm	42.8 ps	29.2	14 GHz

Using offset voltage to extend P7700 series solder-in tip input voltage range

The single-ended linear dynamic range of the TekFlex solder-in tip inputs is specified to be $2.5 V_{p-p}$, which is a range from $-1.25 V$ to $+1.25 V$ with zero volt offset. The dynamic range of P7700 Series buffers is limited by the input attenuation factor, which is 2X for the solder-in probe tips as shown in the following simplified figure. A 2X attenuation factor was selected for the probe tips to optimize dynamic range and noise, since a higher attenuation factor would have increased probe noise. Although the dynamic range of the probe tip buffer cannot be extended, it is possible to extend the range over which the tip dynamic range window can be moved by adjusting the probe offset voltage. The offset voltage range of the TekFlex solder-in tips is $-4 V$ to $+4 V$, which is adjusted using the Probe Setup screen of the oscilloscope or the offset knobs on the oscilloscope front panel. Using the offset voltage controls, it is possible to make measurements within any $2.5 V_{p-p}$ window between $-5.25 V$ and $+5.25 V$. As an example, by setting the offset voltage to $+3.0 V$, it is possible to measure an HDMI signal, which has a signal swing between about $+2.8 V$ and $+3.3 V$.

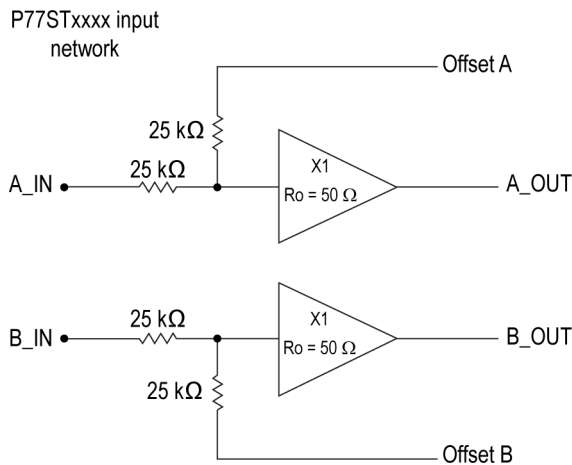

3421-031

Figure 18: Simplified diagram of the P7700 Series probe tip input network

The offset voltage affects the probe tip buffer’s measured signal through a resistive summer configuration that forms the buffer’s input attenuator network. The high value resistors used in the buffer’s input attenuator result in an interaction between the input signal and the offset voltage DC level.

Calibrated offset voltage performance requires that both the input signal and the offset voltage generator in the probe have a source resistance that is very small compared to the 25 kΩ attenuator resistors. The source resistance of the offset voltage generator in the probe is less than 1 Ω. Typically, when the probe and tip are connected to a DUT, the DUT signals have a source resistance R_s much less than 25 kΩ.

If a probe tip is attached to a probe but not soldered to anything, the inputs will be open which effectively makes the source resistance look much larger than the 25 kΩ attenuator resistors. As a result, the offset voltage control is no longer calibrated and will have 2X the calibrated effect on the measured probe output. This effect can be helpful in troubleshooting connection issues with the tips. If a probe tip has been soldered to a DUT and adjusting the offset voltage causes the offset to move 2X the adjustment, it could indicate a broken solder joint that has left the probe tip input open.

Making single-ended measurements using the P77BRWSR differential probe tip

Making single-ended measurements with a TriMode probe tip, such as a TekFlex solder-in tip, is quite straightforward, because a TriMode tip provides solder connections for a DUT ground reference for both the A and B probe inputs. Although the differential input mode of the P7700 Series probe is normally used to make a differential signal measurement, single-ended measurements can be made using Differential Input mode when the probe input connections and offset voltage controls are configured properly. This single-ended configuration process is particularly important to understand when using the P77BRWSR tip, since this variable-spacing Browser tip operates only in Differential Input mode. Differential Input mode provides a measurement of the difference ($A - B$) between the A and B input signals. If the probe tip B input is connected to a DUT ground, the resulting Differential Input mode measurement ($A - 0\text{ V}$) results in a display of the single-ended A input signal response.

When making differential signal measurements, the P77BRWSR Offset Voltage control is normally set to the Common-mode (CM) Tracking mode. With CM tracking mode active, the A and B input signals are monitored and the Offset A and Offset B settings are both adjusted to match the DC common-mode voltage of the A and B input signals $[(A + B)/2]$. When making single-ended measurements in Differential Input mode with a browser tip, the offset voltage control should be set manually, so tracking mode should be shut off. The Offset A voltage should be set manually to the center of the A signal voltage swing. For a +5 V CMOS logic signal; for example, the Offset A voltage should be set to +2.5 V. The A signal input voltage should then range from +5 V to 0 V, which is within the $6\text{ V}_{\text{p-p}}$ dynamic range of the Browser tip as long as the offset voltage is set near the center of its expected voltage swing. The Offset B voltage should also be set manually to 0 V. This Offset B voltage setting is not only at the center of the dynamic range for a grounded B input signal, it also causes the differential offset voltage to equal the Offset A voltage. This is true because the differential offset voltage equals the difference between the Offset A voltage setting and the Offset B voltage setting. The differential offset voltage is used by the oscilloscope as the displayed offset voltage in Differential Input mode.

With the P77BRWSR tip configured for a single-ended measurement in Differential Input mode, the displayed signal voltage should match the A input signal response and the displayed offset voltage should match the Offset A setting. Since the host oscilloscope uses both the displayed signal voltage and displayed offset voltage in calculating its set of available oscilloscope automated measurements, it is important that both the Differential Input mode signal voltage and offset voltage are configured properly as shown in the following figure.

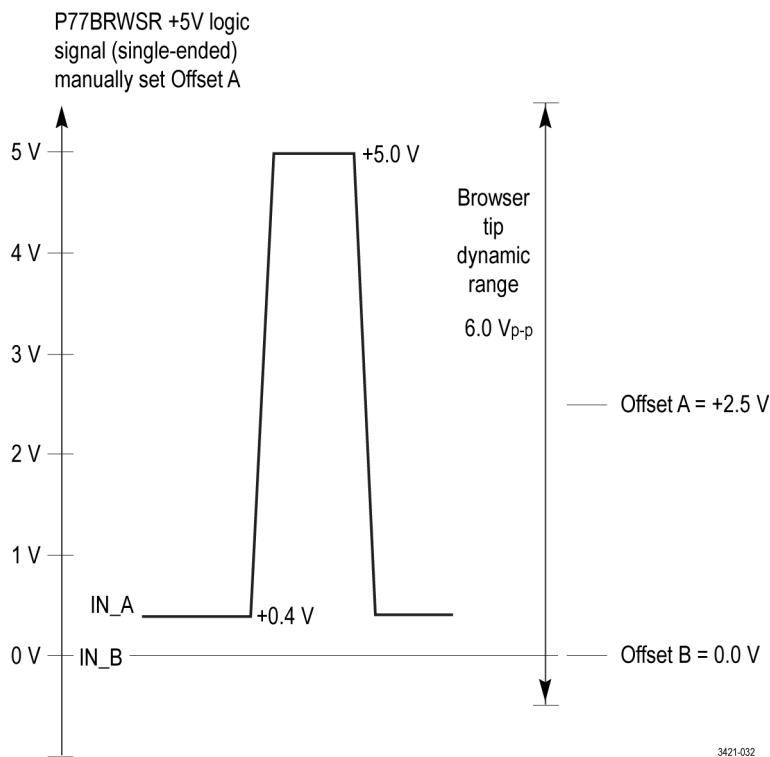

Figure 19: Differential input mode signal voltage and offset voltage

The configuration process described in this section maximizes the available dynamic range of the P77BRWSR tip when making single-ended measurements.

Temperature compensation

The P7700 Series probes employ temperature compensation to optimize measurement accuracy. Whenever a probe setting is changed, such as Input Mode, offset voltage, or vertical scale factor, a temperature compensation update occurs. Continuous temperature compensation is not done to avoid introducing noise into the probe amplifiers.

To maximize measurement accuracy when the probe is first powered on from a cold start condition, you must allow a 20 minute warm-up period for the probe and oscilloscope. After the warm-up period, you should adjust or toggle a probe setting, such as the vertical scale factor, to trigger the temperature compensation update. Otherwise, a cold temperature compensation value might be used, which would result in a small gain error.

Solder tip measurement configuration

In many of the high-frequency signaling standards that the P7700 Series probes are designed for, a 50 Ω termination at the transmitter is in parallel with another 50 Ω termination at the end of the transmission line path, effectively making a 25 Ω signal source impedance. In this application, the solder tip adapter measurement configuration is designed to pick off the transmitted signal at a location in the signal transmission path.

The input impedance for a solder tip, Z probe, varies with frequency. For a P77STxxxx tip the DC input resistance is about 50 k Ω and decreases with frequency above about 10 MHz to about 100 Ω above 10 GHz. Refer to the graphs later in this document for input impedance information. (See page 43, *Input impedance graphs.*)

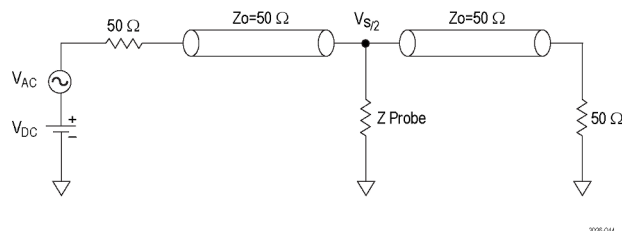

Figure 20: Solder tip measurement configuration

Skew measurements of differential signals

Differential signals are composed of two complementary single-ended signals that generally swing around a common bias voltage. An example of an LVDS differential signal is shown in the following figure.

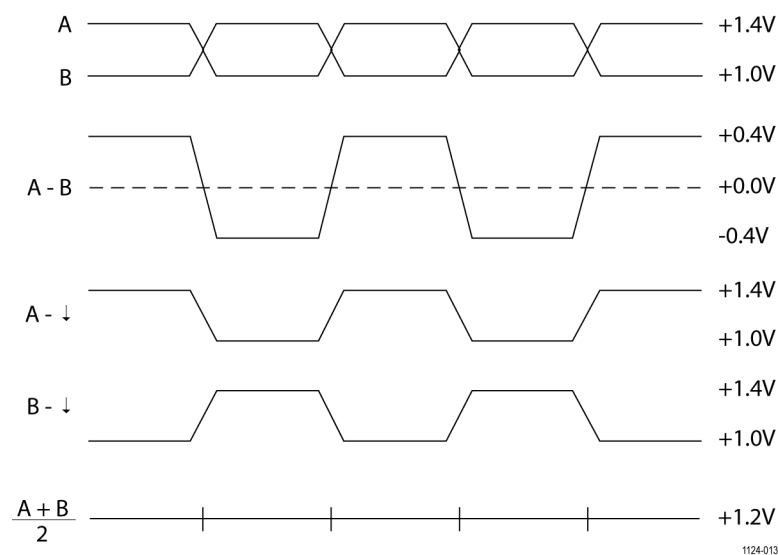

Figure 21: Example of LVDS differential signal

The complementary single-ended signals labeled A and B in the previous figure must have well matched signal timing (for example, low skew) to function as a useful differential signal. If the signal skew becomes comparable in size to the rise time of the complementary signals, then the rise time of the resulting differential signal will be slower than expected. Skew is a measure of the time delay mismatch between two supposedly matched signals.

Although very accurate low skew measurements usually require TDR or VNA measurement equipment, it is possible to make relatively accurate skew measurements of a differential signal pair using a P7700 Series probe and a TriMode probe tip. A flex circuit based solder tip should first be soldered to the DUT differential signal, taking care to match the A and B input wire lengths, because the wiring length mismatch will contribute to the skew measurement error. A DUT ground reference connection should also be made to one of the TriMode tip ground vias using a wire length as short as possible.

At first it might seem reasonable to try to make a skew measurement by directly comparing the A and B signal timing. Although it is possible to display both the single-ended A and B signals that make up the differential signal using the TriMode measurement selection function, both signals cannot be displayed with a single signal acquisition of the oscilloscope. Even though it is possible to capture the A signal and store it as a reference waveform for comparison with a follow-on B signal acquisition, the trigger timing uncertainty between acquisitions might make this a less than accurate, if not impossible approach.

A more indirect, but more accurate, skew measurement should be possible by switching the probe input mode to the common mode setting. Because the common mode setting for a TriMode probe tip features full probe bandwidth, the response should be fast enough to display the relative skew performance. The common mode response for a perfectly matched, zero skew, complementary signal pair should be a flat trace at the common DC bias voltage level. As the skew of the signal pair increases, the common mode waveform begins to show narrow pulses at the signal logic transitions. The pulse width of these narrow transition pulses is a relative measure of the skew.

Reference

This section contains information about taking measurements with the probe and increasing measurement accuracy.

Single-ended measurements

A differential probe, such as a P7700 Series probe, can be used for single-ended measurements within the limits of its dynamic and offset voltage ranges. Single-ended measurements on differential signals are used to measure common mode voltage and check for differential signal symmetry. By using a TriMode probe, you can easily take these measurements with one solder tip DUT connection. (See Table 3.)

Table 3: Single-ended dynamic and offset ranges

Probe	Attenuation	DC offset	Dynamic range
Flex circuit based solder tips (single-ended signals)	4X	± 4 V	$2.5 V_{p-p}$
P77STCABL (single-ended signals)	4X	± 4 V	$2.5 V_{p-p}$
P77BRWSR ¹ , (single-ended signals)	10X	± 10 V	$6.0 V_{p-p}$

¹ The P7700 Series probes have independent A and B input offset controls. To take a single-ended measurement, use the B input for reference and set the B offset to ground or the reference level of the measured signal. Set the A signal offset to the DC common-mode voltage of the measured signal.

Single-ended measurements can be made using P7700 Series TriMode solder tips different ways. If a TriMode solder tip such as a TekFlex solder-in tip includes a soldered ground wire connection to the DUT, then single-ended measurements can be made of either the A or B input signals, depending on the selected Input mode. Selecting the A input mode enables an A input signal measurement, which will be affected by the A offset setting. Selecting the B input mode similarly enables a B signal input and B offset voltage measurement. An example of this TriMode configuration measurement is wiring a single-ended 2.5 V CMOS logic signal to the A input via of a TekFlex solder-in tip, along with a ground via wire connection. In order for the 2.5 V logic signal swing to fit within the probe tip dynamic range, the A offset should be set to +1.25 V, which is the center of the logic signal swing. With the A input mode selected this single-ended logic signal can be measured. In this example, the B input signal can be left open, as long as the B offset is set within ± 0.625 V to keep both probe tip buffer inputs within their linear operating range. The B offset range in this case is limited to half the input signal dynamic range due to the 2X multiplication effect on the offset for an open input. Alternatively, the B input can be connected to another single-ended signal and a separate single-ended measurement can be made by selecting the B input mode with an appropriate B offset setting.

A single-ended measurement can also be made using a TriMode tip in its differential input mode. In this case, the single-ended signal to be measured would be wired to the probe tip A input signal via and the DUT ground reference would be wired to the probe tip B input signal via. No probe tip ground via connection needs to be made with this measurement configuration. Selecting differential input mode enables an A input signal measurement relative to the DUT ground on the B input. In differential input mode both the A offset and B offset settings will affect the measurement. Using the example of a 2.5 V CMOS logic signal, the A offset should again be set to the center of the logic swing at +1.25 V, but the B offset should be set to 0 V to match the DUT ground reference connection.

The dynamic range of the TekFlex solder-in tips limits their use to CMOS logic with a signal swing of no more than 2.5 V. The P77BRWSR Browser probe tip has a larger dynamic range of $6 V_{p-p}$, which should allow measurements of both 3.3 V CMOS logic and 5 V CMOS logic signals. Since the P77BRWSR tip operates only in differential input mode, the browser tip B input connection should be made to the single-ended DUT ground reference. For a 5 V CMOS logic signal measurement example, the A offset voltage should be set to +2.5 V, which is the center of a 5 V CMOS logic swing, and the B offset voltage should again be set to 0 V to match the DUT ground reference.

Differential probes are also ideal for a class of single-ended measurements where the reference voltage is not ground:

- DDR (SSTL_2, STTL_18, SSTL_15): $V_{TT}, V_{REF} = V_{DD} \div 2$
- PECL: $V_{REF} = V_{CC} - 1.3$

To measure single-ended signals in this class, connect the B input of the probe to V_{REF} .

A differential probe in these applications displays the true signal despite any AC or DC variation in V_{REF} from its nominal value. A single-ended probe displays the signal plus the variation in V_{REF} . Differential probes can also be used to make ground referenced single-ended measurements on either single-ended signals or differential signals like PCI Express or Serial ATA.

Differential measurements

A differential probe is optimized to measure high speed differential signals. Differential signals are formed from two complementary signals with a common reference voltage. (See Figure 22.)

Devices designed for differential measurements avoid problems presented by single-ended systems. Differential signal transmission improves signal fidelity by doubling the effective signal amplitude compared to single-ended signal transmission. Differential signaling also improves signal fidelity by removing common mode noise due to the CMRR of the receiver or measurement device.

A differential probe is basically a differential amplifier used to make differential measurements that reject any voltage common to the inputs and amplifies any difference between the inputs. Voltage that is common to both inputs is often referred to as the common-mode voltage (V_{CM}) and voltage that is different as the differential mode voltage (V_{DM}).

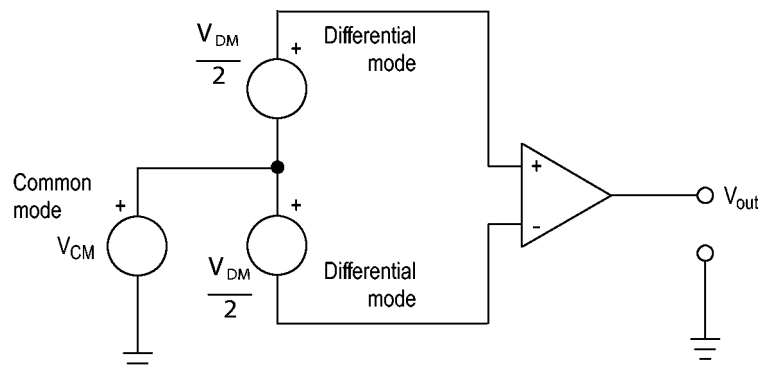

Figure 22: Simplified model of a differential amplifier

Common-mode rejection ratio

Differential amplifiers cannot reject all of the common-mode signal. The ability of a differential amplifier to reject the common-mode signal is expressed as the common-mode rejection ratio (CMRR).

The DC CMRR is the differential-mode gain (A_{DM}) divided by the common-mode gain (A_{CM}). It is expressed either as a ratio or in dB:

$$DC\ CMRR = \frac{A_{DM}}{A_{CM}} \quad DC\ CMRR\ (dB) = 20 \log \left| \frac{A_{DM}}{A_{CM}} \right|$$

AC CMRR for the probe is determined using 3-port, mixed-mode S-parameters for the measured differential mode response, where A input = S1, B input = S2 and Output = S3 is defined as:

$$20 \log \left| \frac{S_{SD21}}{S_{SC21}} \right| - 6\ dB$$

The 6 dB term in the AC CMRR equation gives the voltage-referenced response. CMRR generally is highest (best) at DC and degrades with increasing frequency. A typical CMRR plot for a P7700 Series probe and a flex circuit-based solder tip is shown.

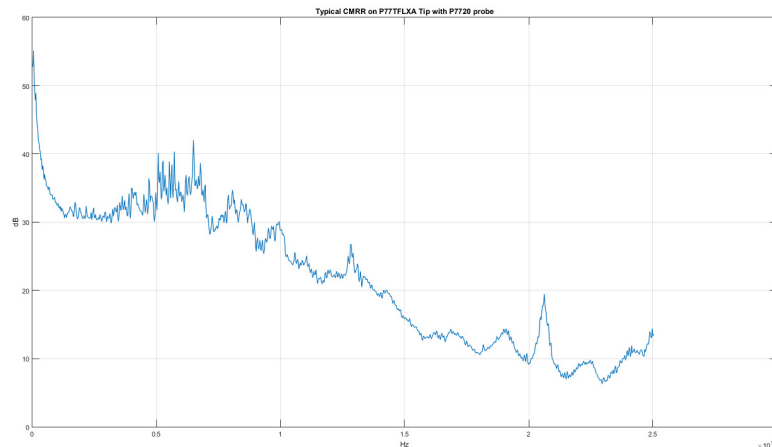

Figure 23: Typical CMRR

Assessing CMRR error

The CMRR of the P7700 Series probes is shown in graphs assuming a sinusoidal common-mode signal. A quick way to assess the magnitude of CMRR error when the common-mode signal is not sinusoidal is to connect both leads to the same point in the circuit. The oscilloscope displays only the common-mode component that is not fully rejected by the probe. While this technique might not yield accurate measurements, it allows you to determine if the magnitude of the common-mode error signal is significant. When using the solder-in tips, keep the tip leads the same length to maximize the probe CMRR.

- Input impedance effects on CMRR** The lower the input impedance of the probe relative to the source impedance, the lower the CMRR for a given source impedance imbalance. Differences in the source impedance driving the two inputs lowers the CMRR. Note that single-ended measurements generally result in asymmetric source impedances which tend to reduce the differential mode CMRR.
- Differential-mode rejection** When making common-mode signal measurements ((A+B)/2 – GND) with the TriMode probe, it is desirable to reject the differential-mode signal present between the two inputs. This rejection is expressed as the Differential-Mode Rejection Ratio (DMRR).
- AC DMRR for the probe is defined using 3-port, mixed-mode S-parameters as:
- $$20 \log \left| \frac{S_{SC21}}{S_{SD21}} \right| + 6 \text{ dB}$$
- for the measured common mode response. The 6 dB term in the AC DMRR equation gives the voltage-referenced response.
- Channel isolation** Under ideal conditions when taking single-ended measurements with a differential probe, no part of a signal applied to one input of the probe would appear on the other input. In reality some portion of the signal on one input does “bleed” over to the other input, and this effect increases with frequency. Channel isolation is a measure of how much crosstalk occurs between the two probe inputs. The channel isolation is defined with S-parameter measurements below, where:
- A input = S1, B input = S2, Output = S3
- $$A \text{ ISOLATION} = 20 \log (S_{31}/S_{32}) \mid A \text{ Mode}$$
- $$B \text{ ISOLATION} = 20 \log (S_{32}/S_{31}) \mid B \text{ Mode}$$

A typical isolation plot for the P7700 Series probes using a flex circuit-based solder tip is shown in the following figure. When the probe is used with P7700 Series solder tips, note that channel isolation performance is highly dependent on probe tip attachment lead length. Good channel isolation requires keeping the interconnect lead length for both signal and ground connections very short.

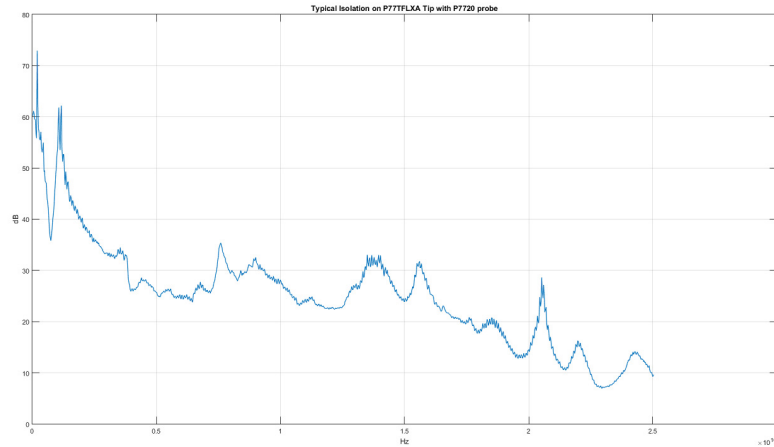

Figure 24: Typical channel isolation

Specifications

These specifications apply to the P7700 Series probes when installed on an MSO/DPO70000DX oscilloscope with a bandwidth greater than or equal to 20 GHz. The probe performance may be degraded if a probe is operated using an oscilloscope with bandwidth less than the probe bandwidth. The probe and oscilloscope must have a warm-up period of at least 20 minutes and be in an environment that does not exceed the allowed environmental limits. (See Table 5.)

Specifications for the P7700 Series TriMode Probes fall into two categories: warranted and typical characteristics.

Warranted characteristics

Warranted characteristics describe guaranteed performance within tolerance limits or certain type-tested requirements.

Table 4: Electrical characteristics

Characteristic	Description		
	Differential mode	A, B mode	Common mode
Rise time, small signal ¹	Bandwidth filtered probe and probe tip fixture rise time, all input modes, and step gain settings		
P7708			
10% – 90%	<55 ps	<55 ps	<57 ps
20% – 80%	<35 ps	<35 ps	<35 ps
P7713			
10% – 90%	<40 ps	<40 ps	<42 ps
20% – 80%	<28 ps	<28 ps	<28 ps
P7716			
10% – 90%	<32 ps	<32 ps	<34 ps
20% – 80%	<24 ps	<24 ps	<24 ps
P7720			
10% – 90%	<27 ps	<27 ps	<29 ps
20% – 80%	<18 ps	<18 ps	<19 ps
DC gain accuracy (probe and probe tip fixture, all input modes and step gain settings)	±2%, nominal DC gain, all gain settings		
Output zero with probe and probe tip fixture (voltage measured at probe output)	±4 mV		

Table 4: Electrical characteristics (cont.)

Characteristic	Description	
	TekFlex solder-in tips	P77BRWSR
Input resistance (A and B inputs) ²		
Differential	104 k Ω , \pm 20%	144 k Ω , \pm 20%
Per side (nominal)	52 k Ω , \pm 20%	72 k Ω , \pm 20%
DC gain accuracy (probe and probe tips, all input modes)	\pm 2%, all gain settings	\pm 2%, all gain settings
Operating voltage window (A and B inputs)	\pm 5.25 V	\pm 10.0 V
Dynamic range (all input modes)	2.5 V _{pp} , single ended input 5.0 V _{pp} , differential input	6.0 V _{pp} , single ended input 12.0 V _{pp} , differential input
Output zero with probe and probe tip (voltage measured at probe output)	\pm 4 mV	\pm 4 mV
Linearity (all input modes and step gain settings)	\pm 1% of dynamic range	\pm 1% of dynamic range

¹ For ambient temperature range of 18 °C to 28 °C (64.4 °F to 82.4 °F) using a 250 mV step

² Specifications are at DC

Table 5: Environmental characteristics

Characteristic	Specification
Temperature, compensation box	
Operating	0 °C to 45 °C (+32 °F to +113 °F)
Nonoperating	-20 °C to +60 °C (-4 °F to +140 °F)
Temperature, probe cable and TkFlex solder-in tips	
Operating	-40 °C to 45 °C (-40 °F to +113 °F) at 10,000 Hours MTBF (No airflow) -46 °C to 85 °C (-51 °F to +185 °F) at 1,000 Hours MTBF (Minimum airflow of 1000 CFM)
Nonoperating	-40 °C to +85 °C (-40 °F to +185 °F)
Temperature, probe cable and P77BRWSR tip	
Operating	0 °C to 45 °C (+32 to +113 °F)
Nonoperating	-20 °C to +60 °C (-4 to +140 °F)
Humidity, comp box	
Operating ¹	8% RH – 80% RH, at up to +32 °C (+104 °F) 5% RH to 45% RH above +32 °C (+104 °F) up to +45 °C (+113 °F) Noncondensing
Nonoperating ²	5% RH – 95% RH, at up to +30 °C (+86 °F) 5% RH to 45% RH above +30 °C (+86 °F) up to +60 °C (+140 °F) Noncondensing
Altitude	
Nonoperating	12,000 meters (40,000 feet)

¹ Limited by maximum wet-bulb temperature of +29.4 °C (+84.9 °F), derates relative humidity to 32% RH at +45 °C (+113 °F)

² Limited by maximum wet-bulb temperature of +29.4 °C (+84.9 °F), derates relative humidity to 11% RH at +60 °C (+140 °F)

Typical characteristics

Typical characteristics describe typical performance without guaranteed limits.

Table 6: Typical electrical characteristics

Characteristic	Description	
	TekFlex solder-in tips	P77BRWSR
Low frequency input capacitance (active tips, A and B inputs)		
Input C, differential	0.4 pF	0.23 pF @ 50 mil spacing 0.22 pF @ 200 mil spacing
Input C, single-ended ¹	0.8 pF	NA
Small signal rise time DSP-corrected, probe tip rise time using a typical probe response (all input modes)		
10% to 90% rise time		
P7720	Differential A and B mode, 27 ps Com mode, 29 ps	Differential mode, 32 ps
P7716	All modes, 32 ps	Differential mode, 32 ps
P7713	All modes, 40 ps	Differential mode, 40 ps
P7708	All modes, 55 ps	Differential mode, 55 ps
20% to 80% rise time		
P7720	Differential A and B mode, 18 ps Com mode, 19 ps	Differential mode, 24 ps
P7716	All modes, 24 ps	Differential mode, 24 ps
P7713	All modes, 28 ps	Differential mode, 28 ps
P7708	All modes, 35 ps	Differential mode, 35 ps
Common mode rejection ratio Unfiltered probe tip and typical probe response (values are voltage based)		
DC	<34 dB	<30 dB
50 MHz	<34 dB	<30 dB
1 GHz	<24 dB	<24 dB
10 GHz	<14 dB	<14 dB
16 GHz	-	<10 dB
20 GHz	<10 dB	-
Differential mode rejection ratio Unfiltered probe tip and typical probe response (values are voltage based)		
50 MHz	<34 dB	N.A.
1 GHz	<24 dB	N.A.
10 GHz	<14 dB	N.A.
20 GHz	<10 dB	N.A.

Table 6: Typical electrical characteristics (cont.)

Characteristic	Description	
	TekFlex solder-in tips	P77BRWSR
Channel isolation	Unfiltered probe tip and typical probe response	
50 MHz	<40 dB	N.A.
1 GHz	<30 dB	N.A.
10 GHz	<15 dB	N.A.
20 GHz	<6 dB	N.A.
Output zero temperature drift	Voltage measured at probe output	
	$\pm 100 \mu\text{V}/^\circ\text{C}$, from -35°C to $+85^\circ\text{C}$ (-31°F to $+185^\circ\text{F}$)	$\pm 100 \mu\text{V}/^\circ\text{C}$, from 0°C to $+45^\circ\text{C}$ ($+32^\circ\text{F}$ to $+113^\circ\text{F}$)
Noise, analog (all Input modes)	$\frac{\leq 32nV}{\sqrt{Hz}}$	$\frac{\leq 80nV}{\sqrt{Hz}}$
Offset voltage range	-4 V to +4 V	-10 V to +10 V
Small signal frequency response ²	DSP corrected, probe tip and typical probe response Differential, A, B, and Common mode	
P7720	≥ 20 GHz	≥ 16 GHz
P7716	≥ 16 GHz	≥ 16 GHz
P7713	≥ 13 GHz	
P7708	≥ 8 GHz	
Auto offset accuracy	$V_{in} \pm 30$ mV	
Offset voltage gain accuracy, probe and probe tips	$\pm 0.5\%$, A and B inputs, all step gain settings	
DC voltage measurement accuracy (referred to input), including major error terms		
4X, ABCD:	$\pm(2\% \text{ of input} + 0.5\% \text{ of offset} + 11.4 \text{ mV} + 3.8 \text{ mV})$	$\pm(2\% \text{ of input} + 0.5\% \text{ of offset} + 27.0 \text{ mV} + 8.9 \text{ mV})$
2X, ABCD:	$\pm(2\% \text{ of input} + 0.5\% \text{ of offset} + 22.8 \text{ mV} + 7.5 \text{ mV})$	$\pm(2\% \text{ of input} + 0.5\% \text{ of offset} + 53.9 \text{ mV} + 17.8 \text{ mV})$
1X, ABC:	$\pm(2\% \text{ of input} + 0.5\% \text{ of offset} + 44.5 \text{ mV} + 12.5 \text{ mV})$	$\pm(2\% \text{ of input} + 0.5\% \text{ of offset} + 107.9 \text{ mV} + 30.0 \text{ mV})$
1X, D:	$\pm(2\% \text{ of input} + 0.5\% \text{ of offset} + 44.5 \text{ mV} + 15.1 \text{ mV})$	$\pm(2\% \text{ of input} + 0.5\% \text{ of offset} + 107.9 \text{ mV} + 35.7 \text{ mV})$
$\frac{1}{2}$ X, D:	$\pm(2\% \text{ of input} + 0.5\% \text{ of offset} + 91.0 \text{ mV} + 25.0 \text{ mV})$	$\pm(2\% \text{ of input} + 0.5\% \text{ of offset} + 215.7 \text{ mV} + 60.0 \text{ mV})$
Nondestructive input voltage range, A and B inputs	-15 V to +15 V (DC + peak AC), tip attached	
Time delay		
P77xx	5.5 ns ± 0.1 ns	
P77STFLXA	260 ps ± 10 ps	
P77STCABL	515 ps ± 10 ps	
P77BRWSR	260 ps ± 10 ps	
Input slew rate	≥ 30 V/ns, single-ended, both inputs	

Table 6: Typical electrical characteristics (cont.)

Characteristic	Description	
	TekFlex solder-in tips	P77BRWSR
System noise DSP (all Input modes)		
P7720	<4.2 mV _{rms}	<11.0 mV _{rms}
P7716	<4.0 mV _{rms}	<11.0 mV _{rms}
P7713	<3.8 mV _{rms}	<10.2 mV _{rms}
P7708	<3.6 mV _{rms}	<8.9 mV _{rms}

1 Single-ended, unused side terminated to 50 ohms

2 Measured as the -3 dB bandwidth for an ambient temperature range of 18 °C to 28 °C (64.4 °F to 82.4 °F)

Table 7: Electromagnetic compatibility (EMC)

Item	Description
Certifications, standards, and classifications	
European Union	EC Council EMC Directive 89/336/EEC, amended by 93/68/EEC Emissions, EN55011, Class A Immunity, IEC61000-4-2 and IEC6100-4-3
Australia	AS/NZS 2064
United States	FCC, CFR Title 47, Part 15, Subpart B, Class A.
Russia	GOST compliance
Emissions	EN55011, Class A
Radiated emissions	EN 55011, Class A Class A, 30-230 MHz at 40 dBuV/m (quasi-peak) at 10 m, 230-1000 MHz at 47 dBuV (quasi-peak) at 10 m Class B, 30-230 MHz at 30 dBuV/m (quasi-peak) at 10 m, 230-1000 MHz at 37 dBuV/m (quasi-peak) at 10 m
Immunity	
Electrostatic discharge (ESD)	IEC 61000-4-2 IEC 61326, Performance Criterion "B"

The following figures show the typical probe performance for the characteristics listed.

Input impedance graphs.

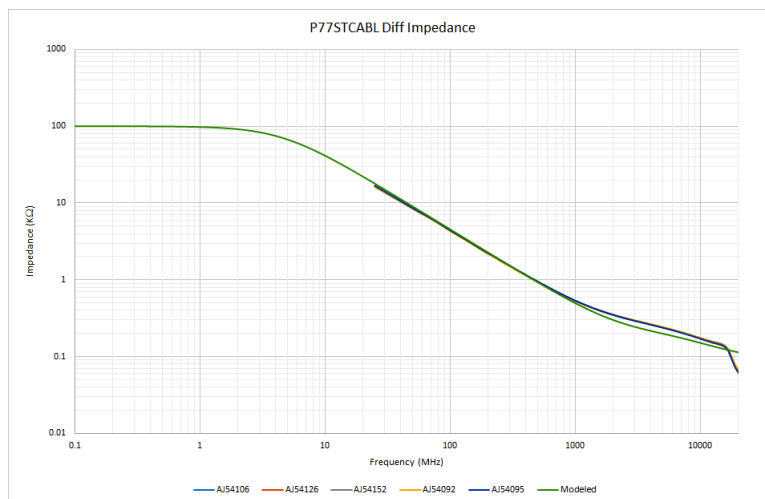

Figure 25: P77STCABL differential impedance

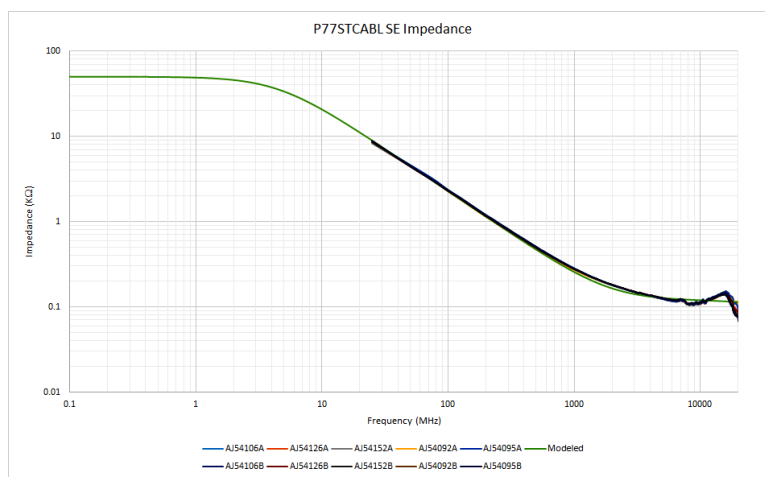

Figure 26: P77STCABL SE impedance

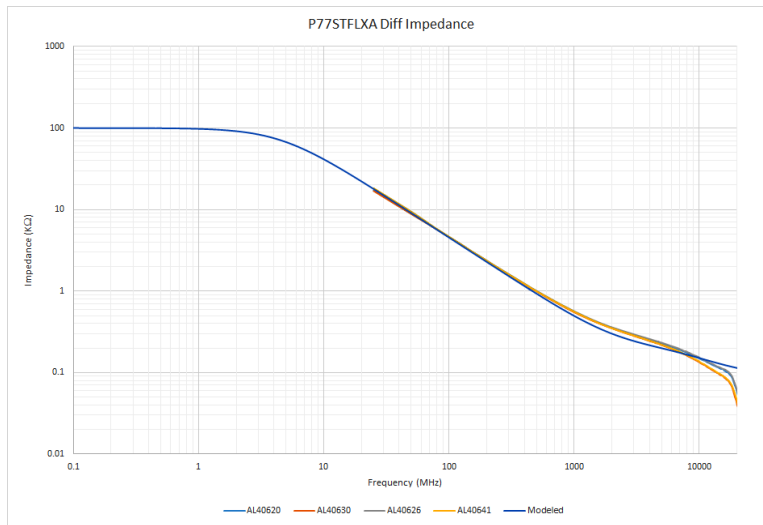

Figure 27: P77STFLXA differential impedance

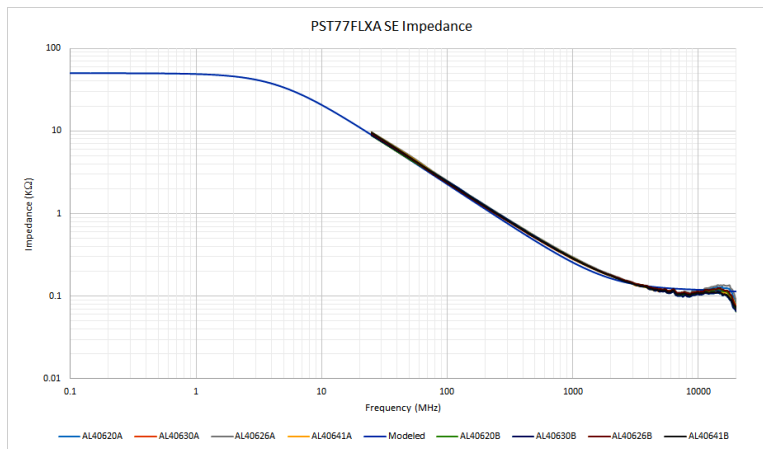

Figure 28: PST77FLXA SE impedance

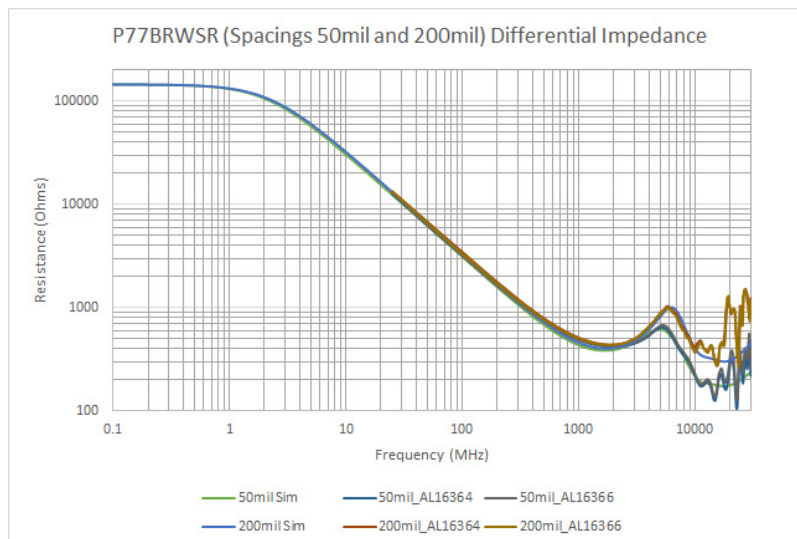

Figure 29: P77BRWSR differential impedance

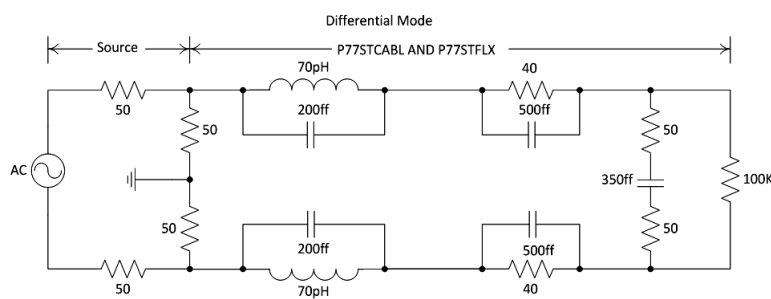

Figure 30: Differential mode P77STCABL and P77FLXA equivalent circuit diagram

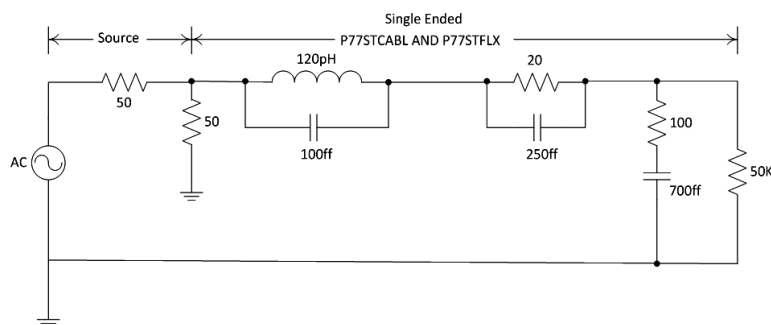

Figure 31: Single-ended P77FLXA equivalent circuit diagram

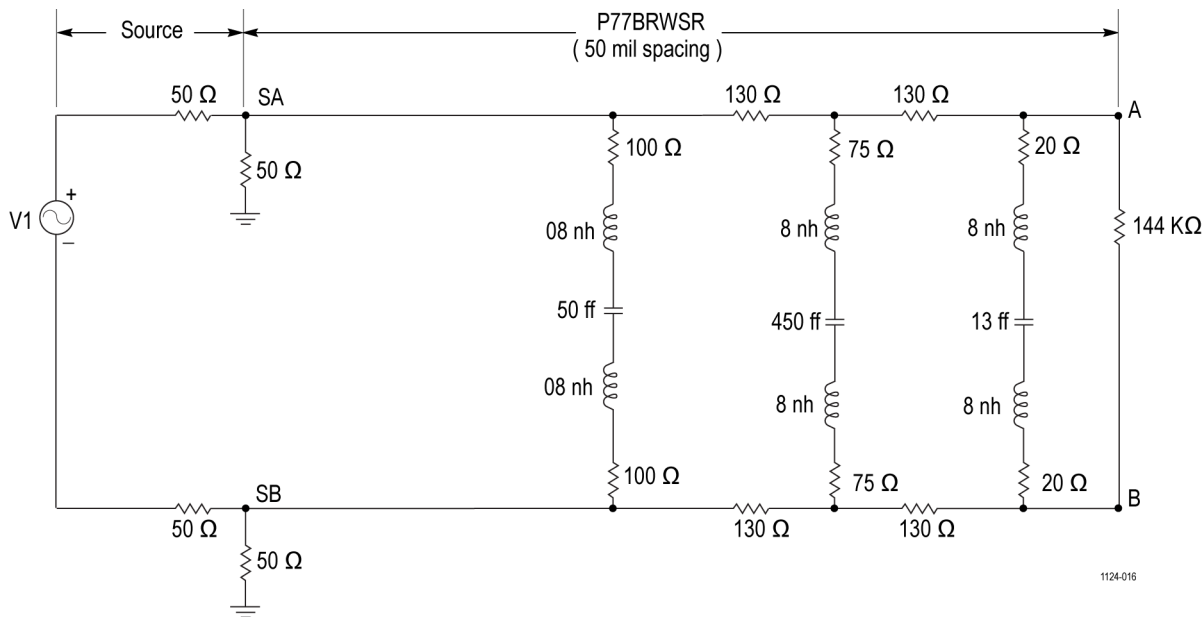

Figure 32: P77BRWSR equivalent circuit diagram with 50 mil spacing

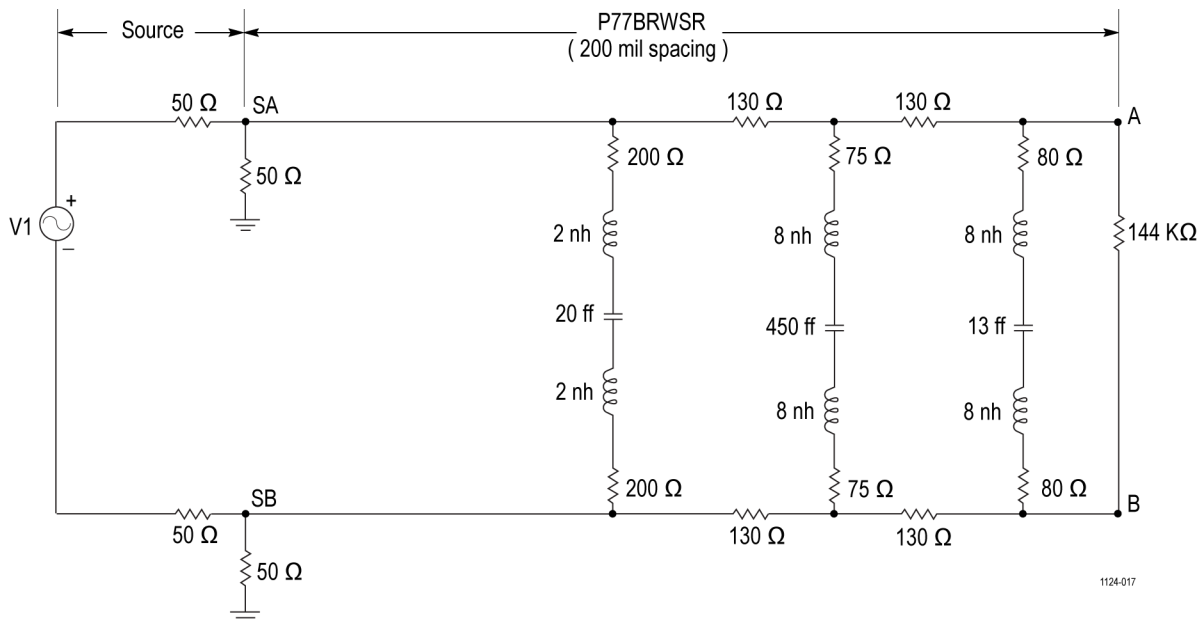

Figure 33: P77BRWSR equivalent circuit diagram with 200 mil spacing

Host instrument firmware

Some oscilloscopes might require a firmware upgrade to support full functionality of the P7700 Series probes. Instruments with lower versions of firmware might not display all probe controls and indicators on screen, and in some cases require you to power-cycle the instrument to restore normal instrument operation.

The following table lists the required versions of instrument firmware for some of the oscilloscopes that currently support the P7700 Series probes.

Instrument	Firmware Version
MSO/DSA/DPO70000C Series oscilloscope	V 7.6 or higher
DSA/DPO70000D Series oscilloscope	V 7.6 or higher
MSO/DPO70000DX Series oscilloscope	V 7.6 or higher
DSO70000SX Series oscilloscopes	V 10.4 or higher

To check the firmware version on Windows-based instruments, from the menu bar, click Help/About TekScope. If you need to upgrade your instrument firmware, go to www.tek.com/downloads to download the latest firmware.



Index

B

browser tip dynamic range, 27

C

cable assembly, 2
channel isolation, 35
CMRR, 34
 assessing CMRR error, 34
common-mode rejection ratio, 34
comp box, 2
correction filtering, 21

D

DC probe calibration, 22
differential measurements, 32
differential signals
 skew measurements, 29
Differential-Mode rejection
 ratio, 35
DMRR, 35
DSP correction filtering, 21
dynamic range
 browser tip, 27

F

firmware upgrade, 47

H

host instrument firmware, 47

I

input network, 26
input signal dynamic range, 16
input voltage, 13
input voltage range
 extend using offset
 voltage, 25

O

offset voltage, 18
operating voltage window, 13
operating voltages, 12

P

probe calibration, 22
probe components, 2
probe input architecture, 5

S

single-ended measurements, 31
 using browser differential
 probe tip, 27
skew
 defined, 29
skew measurements
 differential signals, 29
specifications
 typical, 40
 warranted, 37

T

TekConnect interface, 8
TekFlex connector, 3
temperature compensation, 28
TriMode differential probe tip
 making single-ended
 measurements, 27
TriMode operation, 10

W

wire length
 solder-in tip connection, 22

